

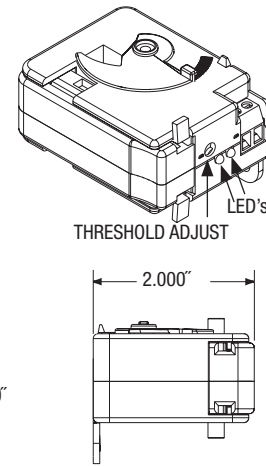

## Current Sensors Low-Voltage Switching

### RIBXG Series Enclosed Split Core Current Sensors

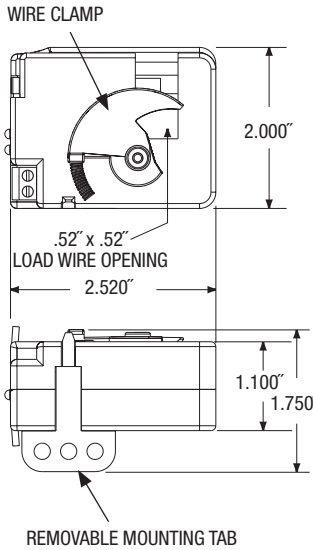

Solid State Contact  
30 Vac/dc, .4 Amp Max.

When current sensor status is off (open),  
leakage <30 uA @ 30Vac/dc  
When current sensor status is on (closed)  
voltage drop < .3 Vac/dc @ .1 Amp  
< 1.6 Vac/dc @ .4 Amp

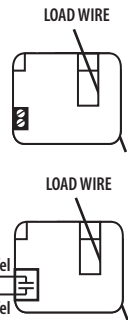

#### SPECIFICATIONS

- Operating Temperature: -30 to 140° F
- Max Sense Voltage: 600 Vac
- Approvals: UL Listed, UL916, UL864, C-UL, CE, RoHS
- Housing Rating: Plenum, NEMA 1
- Mounting/Installation: Removable mounting tab provided. The wire clamp locks against the load wire, securing the unit in place.

## Self-Calibrating Current Sensors (Models with -SCAL Suffix)

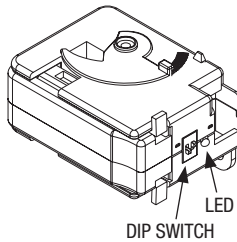

#### -SCAL LED Table

LED Off	No Current
Two Winks	Current Below Range
Three Winks	Current In Range
Four Winks	Current Above Range
Continuous Winks	Calibration in Progress

The SCAL unit begins the 30 second self-calibration process the first time current is applied in the operating range. The threshold is permanently set. Subsequent calibrations may be performed by moving SW1 to the position opposite of its current position with or without current applied (hands can be safely away from live voltage). Once current begins flowing, or if it already is, the calibration process will begin. At the end of the 30 seconds, amperage will be read and set as the threshold. SW2 in the ON position provides a 15% (+/-3%) differential, in the OFF position it provides a 25% (+/-3%) differential. SW2 can be selected at anytime and does not affect the threshold setting. Current in-range closes the status contacts. Current above or below range opens the status contacts. Ex. With a current of 10 amps set as the threshold and a 15% differential, status contacts will be closed between 8.5 amps and 11.5 amps and open outside of this range. A small amount of hysteresis is provided to prevent dithering near the differential limits.

## RIBXG Series Selection Guide

MODEL #	RANGE	TYPE	THRESHOLD	OUTPUT	LED 1	LED 2
RIBXGF	.35-150 Amp	Split Core	Fixed, .35 Amp	Solid State Switch SPST ; 30 Vac/dc ; .4 Amps Max (Wht/Yel 16" 18 AWG Wire Leads)		
RIBXGFL	.75-150 Amp	Split Core	Fixed, .75 Amp	Solid State Switch SPST ; 30 Vac/dc ; .4 Amps Max (Wht/Yel 16" 18 AWG Wire Leads)	Over Trip Point	
RIBXGTF	.35-150 Amp	Split Core	Fixed, .35 Amp	Solid State Switch SPST ; 30 Vac/dc ; .4 Amps Max (Terminal Strip, Accepts #14-22 AWG Wire)		
RIBXGTFL	.75-150 Amp	Split Core	Fixed, .75 Amp	Solid State Switch SPST ; 30 Vac/dc ; .4 Amps Max (Terminal Strip, Accepts #14-22 AWG Wire)	Over Trip Point	
RIBXGA	.75-150 Amp	Split Core	Adjustable	Solid State Switch SPST ; 30 Vac/dc ; .4 Amps Max (Wht/Yel 16" 18 AWG Wire Leads)	Over Trip Point	Under Trip Point
RIBXGTA	.75-150 Amp	Split Core	Adjustable	Solid State Switch SPST ; 30 Vac/dc ; .4 Amps Max (Terminal Strip, Accepts #14-22 AWG Wire)	Over Trip Point	Under Trip Point
RIBXGA-SCAL	3-150 Amp	Split Core	Self-Cal.	Solid State Switch SPST ; 30 Vac/dc ; .4 Amps Max (Wht/Yel 16" 18 AWG Wire Leads)	See -SCAL Table	
RIBXGTA-SCAL	3-150 Amp	Split Core	Self-Cal.	Solid State Switch SPST ; 30 Vac/dc ; .4 Amps Max (Terminal Strip, Accepts #14-22 AWG Wire)	See -SCAL Table	