



SPECIFICATIONS

Transformer: Two 40 VA Split-Bobbin
Over Current Protection: Circuit Breaker

Input Wires: "B10" Models Only
Input Power Wires
 BLK: 120 Vac
 WHT: Neutral
 GRN: Ground

All Other Models
Primary Wires
 BLK: 120 Vac
 WHT: Common

Outlet Wires
 BLK: 120 Vac
 WHT: Neutral
 GRN: Ground

Output Wires: "B10" Models Only
Auxiliary Output
 BLU: 120 Vac

"W" Models Only
Transformer Output
 WHT/YEL: 24 Vac
 WHT/BLU: Common

Frequency: 50/60 Hz
24 Vac ON/OFF: On / Off Switch & Breaker
Main Breaker ON/OFF: Switch / Breaker (10 Amp)
 (Kills power to entire unit: Outlets (if Present), Aux. Output, and Transformer)**
Approvals: Class 2 UL Listed, UL916, UL508, C-UL, CE, RoHS
Dimensions: 4.500" x 8.625" x 4.500"
Weight: 5.400 lbs.

AC Power Supply

PSH40A40A Series

Enclosed Dual 40 VA Power Supplies, 120 to 24 Vac

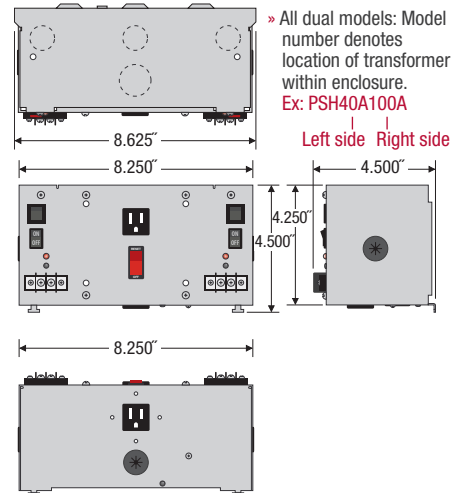
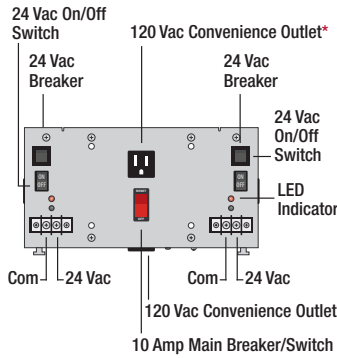

Notes:

- *Move internal jumper to "HOT" position if you wish outlets to always be hot otherwise outlets will be switched by main breaker.
- » To order UL508, add "-IC" to end of model number.

PSH40A40A Series Selection Guide

MODEL #	120 VAC OUTLETS	AUX OUTPUT WIRE	MAIN BREAKER ON INPUT POWER	SECONDARY CONFIGURATION
PSH40A40A	•			External Terminal Strip
PSH40A40AN				External Terminal Strip
PSH40A40ANW				Internal Wires
PSH40A40AW	•			Internal Wires
PSH40A40AB10**	•	•	10 Amp Switch / Breaker	External Terminal Strip
PSH40A40ANB10**		•	10 Amp Switch / Breaker	External Terminal Strip
PSH40A40ANWB10**		•	10 Amp Switch / Breaker	Internal Wires
PSH40A40AWB10**	•	•	10 Amp Switch / Breaker	Internal Wires

Notes