

We'll help solve any application problem with a wide range of accessories and unparalleled customer service.

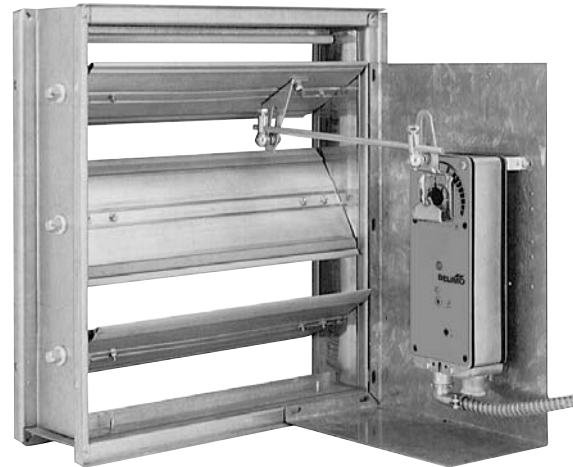

## The Belimo Difference

- Customer Commitment.**  
 Extensive product range. Competitive project pricing. Application assistance.  
 Same-day shipments. Free technical support. Five year warranty.
- Low Installation and Life-Cycle Cost.**  
 Easy installation. Accuracy and repeatability.  
 Low power consumption. No maintenance.
- Long Service Life.**  
 Components tested before assembly. Every product tested before shipment.  
 20+ years direct coupled actuator design.

M40024 - 05/10 - Subject to change. © Belimo Aircontrols (USA), Inc.

	Part Number	Description	AFB	AF	NFB	LF	TF	GM	AM	NM	LM	AH	LH	LU
<b>Clamp / Positioner Indicators</b>	IND-AFB	Damper Position Indicator	●		●									
	IND-AF2	Damper Position Indicator		●										
	IND-LF	Damper Position Indicator				●								
	IND-TF	Damper Position Indicator					●							
	K7-2	Standard AFB/NFB Clamp (1/2" to 1.05")	●		●									
	K4-2 US	Standard AF/NF Clamp (1/2" to 1.05")		●										
	K4-1 US	Jackshaft Clamp (Up to 1.05')		●										
	K4-H US	Hex Shaft Clamp (3/8" to 5/8")		●										
	K6 US	Standard LF Clamp (3/8" to 1/2")				●								
	K6-1	Jackshaft Clamp (1/2" to 3/4")				●								
	K8 US	Standard TF Clamp					●							
	K-GM20	Reversible Clamp (1/2" to 1.05")						●						
	K-AM25	Standard Clamp (1/2" to 1")							●					
	K-SA	Reversible AM Clamp (2/5" to 3/4")							●					
	K-NA	Reversible NM Clamp (5/16" to 3/4")								●				
	K-LM20	Clamp (3/4")										●		
	K-LM16	Standard Clamp (5/8")										●		
	K-LM13	Clamp (1/2")										●		
	K-LM10	Clamp (3/8")										●		
	K-LU	Spindle Clamp (5/16" to 1/2")												●
<b>Linkage Accessories</b>	KH-AFB	Crank Arm	●		●									
	KH-AF	Crank Arm		●										
	KH-AF-1 US	Crank Arm for Jackshaft Applications		●										
	KH-AFV	V-Bolt Kit for KH-AF (-1) Crank Arms		●										
	KH-LF	Crank Arm				●								
	KH-LFV	V-Bolt Kit for KH-LF Crank Arms				●								
	KH-TF US	Crank Arm					●							
	AH-GMA	GMB(X) Crank Arm						●						
	AH-25	AMB(X) and NMB(X) Crank Arm							●	●				
	KH6	Universal Crank Arm (For KG6 Ball Joint)		●	●	●	●	●	●	●		●	●	
	KH8	Universal Crank Arm (For KG8 Ball Joint)		●	●	●	●	●	●	●		●	●	
	KH10	Universal Crank Arm (For KG10A Ball Joint)	●	●	●	●	●	●	●	●				
	KH12	Universal Crank Arm (For KG10A Ball Joint)	●	●	●	●	●	●	●	●				
	KG6	Ball Joint (5/16")		●	●	●	●	●	●	●		●	●	
	KG8	Ball Joint (5/16", 90)		●	●	●	●	●	●	●	●	●	●	
	KG10	Ball Joint for KH6 (3/8")		●	●	●	●	●	●	●		●	●	
	SH8	Push Rod for KG6 & KG8 Ball Joints (36", 5/16" Dia.)		●	●	●	●	●	●	●		●	●	
	SH10	Push Rod for KG10 Ball Joints (36", 3/8" Dia.)		●	●	●	●	●	●	●		●	●	
	ZG-DC1	Damper Clip for Damper Blade		●	●	●	●	●	●	●		●	●	
	ZG-DC2	Damper Clip for Damper Blade		●	●	●	●	●	●	●		●	●	

M40024 - 05/10 - Subject to change. © Belimo Aircontrols (USA), Inc.

	Part Number	Description	AFB	AF	NFB	LF	TF	GM	AM	NM	LM	AH	LH	LU
Brackets	ZG-100	Universal Mounting Bracket	●	●	●			●	●					
	ZG-101	Universal Mounting Bracket	●	●	●			●	●					
	ZG-102	Multiple Actuator Mounting Bracket	●	●				●	●					
	ZG-103	Universal Mounting Bracket						●	●	●				
	ZG-104	Universal Mounting Bracket						●	●	●				
	ZG-106	Universal Mounting Bracket		●										
	ZG-107	Universal Mounting Bracket		●										
	ZG-108	Universal Mounting Bracket		●										
	ZG-109	Mounting Bracket for ZS-260 Housings	●	●	●	●		●	●					
	ZG-110	Mounting Bracket for ZS-260 Housings	●	●	●	●		●	●					
	ZG-112	Universal Mounting Bracket for LF				●								
	ZG-113	Universal Mounting Bracket for TF					●							
	ZG-118	Universal Mounting Bracket for AFB, NFB	●		●									
	Z-GMA	GM to GMB(X) Retrofit Mounting Bracket						●						
	Z-SMA	AM, SM to AMB(X) Retrofit Mounting Bracket							●					
	Z-NMA	NM to NMB(X) Retrofit Mounting Bracket								●				
Crank arm Adaptor Kits	ZG-AFB	Crank Arm Adaptor Kit	●		●									
	ZG-AFB118	Crank Arm Adaptor Kit	●		●									
	ZG-AF US	Crank Arm Adaptor Kit (includes mounting hardware)		●										
	ZG-AF108	Crank Arm Adaptor Kit (includes ZG-108 & KH-AF US)		●										
	ZG-LF112	Crank Arm Adaptor Kit (includes ZG-112 & KH-LF)				●								
	ZG-LF2	Crank Arm Adaptor Kit (includes mounting hardware)				●								
	ZG-LFC114	Trane Voyager Retrofit Kit (includes retrofit bracket)				●								
	ZG-ECON1	Honeywell Economizer Retrofit Kit (includes retrofit bracket)				●								
	ZG-ECON2	Honeywell Economizer Retrofit Kit				●								
	ZG-TF112	Crank Arm Adaptor Kit (includes ZG-113 & KH-TF US)					●							
	ZG-TF2	Crank Arm Adaptor Kit (includes mounting hardware)					●							
	ZG-GMA	Crank Arm Adaptor Kit (includes mounting hardware)						●						
ZG-NMA	Crank Arm Adaptor Kit (includes mounting hardware)							●	●					
Shaft Adaptors	AV6-20	Shaft Extension fits 1/4" to 3/4" Diameter Shafts				●	●				●			
	AV8-25	Shaft Extension fits 5/16" to 1" Diameter Shafts	●	●	●	●		●	●	●				
	ZG-JSA (-1,2,3)	Jackshaft Adaptors for Hollow Jackshafts	●	●	●			●	●	●				
	ZG-LMSA(-1)	Shaft Adaptor									●			
	ZG-NMSA-1	Shaft Adaptor								●				
Rotation Limiters	ZDB-AF2 US	Angle of Rotation Limiter for AF/NF		●										
	ZDB-LF	Angle of Rotation Limiter for LF				●								
	ZDB-TF	Angle of Rotation Limiter for TF					●							
	ZDB-LU	Angle of Rotation Limiter for LU												●
Housings	ZS-100	Weather Shield - Galvaneal	●	●	●	●		●	●					
	ZS-101	Base for ZS-100	●	●	●	●		●	●					
	ZS-150	Weather Shield - Polycarbonate	●	●	●	●		●	●					
	ZS-260	Explosion Proof Housing	●	●	●	●		●	●					
	ZS-300 (-1) (-5)	NEMA 4X Housing	●	●	●	●		●	●					
	ZS-T	Protective Terminal Strip Cover (-T Models Only)						●	●	●	●			

M40024 - 05/10 - Subject to change. © Belimo Aircontrols (USA), Inc.

	Part Number	Description	AFB	AF	NFB	LF	TF	GM	AM	NM	LM	AH	LH	LU	
<b>Miscellaneous</b>	AF-CC US	Conduit Connector		●											
	TF-CC US	Conduit Connector	●		●		●	●	●	●	●	●	●	●	
	AF-P	Anti-Rotation Bracket (11414)	●	●	●										
	LF-P	Anti-Rotation Bracket (11695)				●									
	TF-P	Anti-Rotation Bracket (11533)					●				●				
	Z-DS1	Rotary Support for Lateral Force Compensation											●	●	
	Tool-06	8 mm and 10 mm Wrench	●	●	●	●	●		●	●	●	●	●	●	
	<b>Tool-07</b>	13 mm Wrench						●							

**Clamps / Position Indicators / Rotation Limiters**

**K7-2 US** Standard Clamp. Fits shafts 1/2" to 1.05".



**IND-AFB** Damper Position Indicator.  
For damper position indication in short shaft installations



**Shaft Adaptors / Extensions**

**AV8-25** Shaft Extension. For damper operating shafts.  
Approx. 6-5/8" [170 mm] extension for shafts  
1/4" to 3/4" [6 to 20 mm].



The shaft adaptors listed below may be used with AFB, AFX, NFB, NFX actuators.  
For more information see page 410.

**ZG-JSA-1 ZG-JSA-2 ZG-JSA-3**

**Non-Direct Mounting**

**ZG-AFB** Crank Arm Adaptor Kit  
For more information see page 401.

**ZG-AFB118** Crank Arm Adaptor Kit  
For more information see page 396.

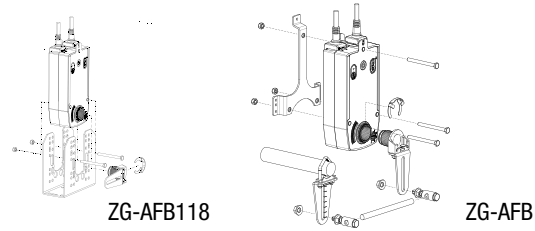

**KH-AFB** Crank Arm  
Fits round shafts up to 3/4".



**Mounting Brackets**

The mounting brackets listed below may be used with AFB, AFX, NFB, NFX actuators.  
For more information see pages 395, 396 and 405.

**ZG-100 ZG-101 ZG-102 ZG-118**

**Housings**

The housings listed below may be used with AF/NF actuators.  
For more information see pages 411 to 415.

**ZS-100 ZS-150 ZS-260 ZS-300**

**Miscellaneous**

**AF-P** Anti-Rotation T-Bracket for AF/NF.

**Z-AF** AF, NF to AFB, AFX, NFB, NFX Retrofit Mounting Bracket

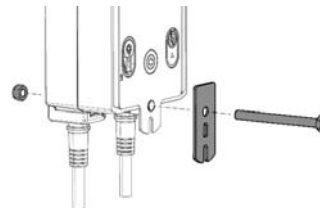

M40024 - 05/10 - Subject to change. © Belimo Aircontrols (USA), Inc.

### Clamps / Position Indicators / Rotation Limiters

**K4 US** Clamp. Fits shafts 3/8" to 3/4".

**K4-1 US** Jackshaft Clamp. Fits jackshafts up to 1.05".

**K4-2 US** Standard Clamp. Fits shafts 1/2" to 1.05".

**K4-H** Hex Shaft clamp. Fits hex shafts 3/8" to 5/8".

**IND-AF2** Damper Position Indicator.  
For damper position indication in short shaft installations.

**ZDB-AF2 US US** Angle of Rotation Limiter for AF/NF actuators. Includes IND-AF2.

**KH-AFV** V-Bolt Kit allows for direct coupling with KH-LF.  
Contains V-Bolt and 2 nuts.



### Shaft Adaptors / Extensions

**AV8-25** Shaft Extension. For damper operating shafts.  
Approx. 6-5/8" [170 mm] extension for shafts  
1/4" to 3/4" [6 to 20 mm].



The shaft adaptors listed below may be used with AF/NF actuators.  
For more information see page 410.

**ZG-JSA-1 ZG-JSA-2 ZG-JSA-3**

### Non-Direct Mounting

**ZG-AF US** Crank Arm Adaptor Kit  
For more information see page 402.

**ZG-AF108** Crank Arm Adaptor Kit  
For more information see page 398.

**KH-AF** Crank Arm  
Fits round shafts up to 3/4".

**KH-AF-1 US** Crank Arm for Jackshaft Applications  
Fits round shafts up to 1.05".

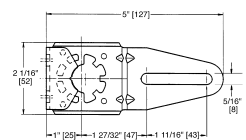

### Mounting Brackets

The mounting brackets listed below may be used with AF/NF actuators.  
For more information see pages 395, 398, 400 and 405.

**ZG-100 ZG-101 ZG-102 ZG-106 ZG-107 ZG-108**

### Housings

The housings listed below may be used with AF/NF actuators.  
For more information see pages 411 to 415.

**ZS-100 ZS-150 ZS-260 ZS-300**

### Miscellaneous

**AF-P** Anti-Rotation T-Bracket for AF/NF.

M40024 - 05/10 - Subject to change. © Belimo Aircontrols (USA), Inc.

**Clamps / Position Indicators / Rotation Limiters**

**K6 US** Clamp. Fits shafts 3/8" to 1/2".

**K6-1** Clamp. Fits shafts 1/2" to 3/4".

**IND-LF** Damper Position Indicator



**ZDB-LF** Angle of Rotation Limiter for LF actuators

**KH-LFV** V-Bolt Kit allows direct coupling with KH-LF. Contains V-Bolt and 2 nuts.



**Shaft Adaptors / Extensions**

**ZG-LMSA-1** Shaft Adaptor (See LM Accessories)

**AV6-20** Shaft Extension. For damper operating shafts. Approx. 6 5/8" [170 mm] extension for shafts 1/4" to 3/4" [6 to 20 mm] (must use K6-1 clamp).



**AV8-25** Shaft Extension. For damper operating shafts. Approx. 9.8" [170 mm] extension for shafts 5/16" to 1" [8 to 10 mm].

**Non-Direct Mounting**

**ZG-LF112** Crank Arm Adaptor Kit  
For more information see page 406.

**ZG-LF2** Crank Arm Adaptor Kit  
For more information see page 407.

**ZG-LFC114** Crank Arm Adaptor Kit  
Specifically for Trane Voyager unit retrofit  
For more information see page 408.

**ZG-ECON1** Crank Arm Adaptor Kit  
Specifically for Honeywell economizer retrofit  
For more information see page 409.

**ZG-ECON2** Crank Arm Adaptor Kit  
Specifically for Honeywell economizer retrofit  
For more information see page 409.

**KH-LF** Crank Arm

**ZG-LF112**



**ZG-LF2**

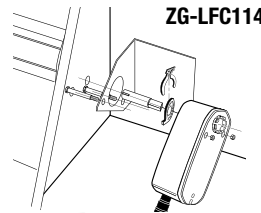

**ZG-LFC114**

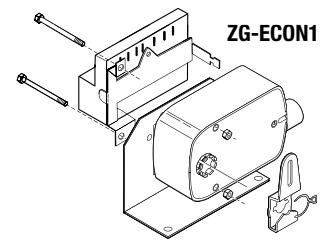

**ZG-ECON1**



**KH-LF**

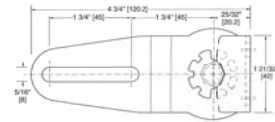

**Mounting Brackets**

The mounting brackets listed below may be used with LF actuators. For more information see page 406.

**ZG-112**

**Housings**

The housings listed below may be used with LF actuators. For more information see pages 411 to 413.

**ZS-100 ZS-150 ZS-260**

**Miscellaneous**

**LF-P** Anti-Rotation T-Bracket for LF.

M40024 - 05/10 - Subject to change. © Belimo Aircontrols (USA), Inc.

### Clamps / Position Indicators / Rotation Limiters

- IND-TF**                      Damper Position Indicator

---

- ZDB-TF**                      Angle of Rotation Limiter for TF actuators.

### Shaft Adaptors / Extensions

- AV6-20**                      Shaft Extension. For damper operating shafts.  
Approx. 6-5/8" [170 mm] extension for shafts  
1/4" to 3/4" [6 to 20 mm].



### Non-Direct Mounting

- ZG-TF112**                      Crank Arm Adaptor Kit.  
For more information see page 406.

---

- ZG-TF2**                      Crank Arm Adaptor Kit.  
For more information see page 407.

---

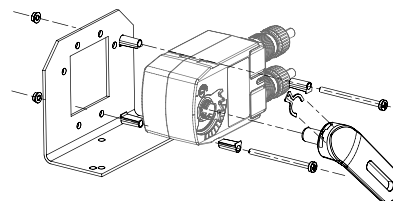
- KH-TF US**                      Crank Arm.  
With 5/16" slot (can be used with KG8 or KG10A Ball Joint).

---

- KH-TF-1 US**                      Crank Arm.  
With 1/4" slot (can be used with KG6 Ball Joint).

---

### Mounting Brackets

The mounting brackets listed below may be used with TF actuators.  
For more information see page 406.

- ZG-113**

### Housings

The housings listed below may be used with TF actuators.  
For more information see page 411.

- ZS-100      ZS-150**

### Miscellaneous

- TF-CC US**                      Conduit Connector for AFB(X) / NFB (X) / TF / GM / AM / NM / LM

---

- TF-P**                      Anti-Rotation T-Bracket for TF / LM.

---



**Clamps / Position Indicators / Rotation Limiters**

**K-GM20** Reversible Clamp. Fits shafts up to 1.05".



**Shaft Adaptors**

**AV8-25** Shaft Extension. For damper operating shafts. Approx. 9.8" [170 mm] extension for shafts 5/16" to 1" [8 to 10 mm].



The shaft adaptors listed below may be used with GM actuators. For more information see page 410.

**ZG-JSA-1 ZG-JSA-2 ZG-JSA-3**

**Non-Direct Mounting**

**ZG-GMA** Crank Arm Adaptor Kit  
For more information see page 403.

**AH-GMA** Crank Arm

**23681-00001** GK Adaptor. For short shafting to connect to auxiliary switch or potentiometer.

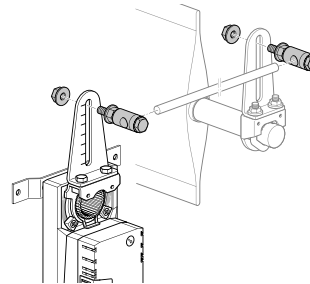

**Mounting Brackets**

The mounting brackets listed below may be used with GM actuators. For more information see pages 395 and 405.

**ZG-100 ZG-101 ZG-102 ZG-103 ZG-104**

**Housings**

The housings listed below may be used with GM actuators. For more information see pages 411 to 415 and page 372.

**ZS-100 ZS-150 ZS-260 ZS-300 ZS-T**

**Miscellaneous**

**TF-CC US** Conduit Connector for AFB, AFX / NFB, NFX / TF / GM / AM / NM / LM

**Z-GMA** GM to GMB, GMX Retrofit Mounting Bracket.

## Clamps / Position Indicators / Rotation Limiters

**K-AM25** Standard Reversible Clamp. Fits shafts up to 1.05".

**K-SA** Reversible Clamp. Fits shafts up to 3/4".



## Non-Direct Mounting

**ZG-NMA** Crank Arm Adaptor Kit  
For more information see page 404.

**AH-25** Crank Arm



## Shaft Adaptors / Extensions

**AV8-25** Shaft Extension. For damper operating shafts.  
Approx. 9.8" [170 mm] extension for shafts  
5/16" to 1" [8 to 10 mm].



The shaft adaptors listed below may be used with AM actuators.  
For more information see page 410.

**ZG-JSA-1 ZG-JSA-2 ZG-JSA-3**

## Mounting Brackets

The mounting brackets listed below may be used with AM actuators.  
For more information see page 405.

**ZG-100 ZG-101 ZG-103 ZG-104**

## Housings

The housings listed below may be used with AM actuators.  
For more information see pages 411 to 415 and page 372.

**ZS-100 ZS-150 ZS-260 ZS-300 ZS-T**

## Miscellaneous

**TF-CC US** Conduit Connector for AFB, AFX / NFB, NFX / TF / GM / AM / NM / LM

**Z-SMA** AM, SM to AMB, AMX Retrofit Mounting Bracket

**Clamps / Position Indicators / Rotation Limiters**

**K-AM25** Standard Reversible Clamp. Fits shafts up to 1.05".

**K-NA** Reversible Clamp. Fits shafts up to 3/4".



**Non-Direct Mounting**

**ZG-NMA** Crank Arm Adaptor Kit  
For more information see page 404.

**AH-25** Crank Arm

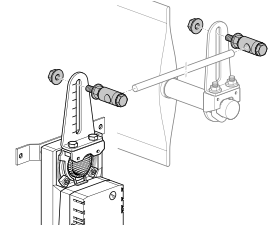
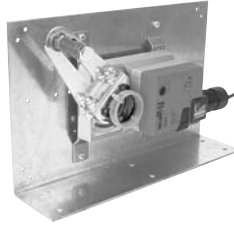

**Shaft Adaptors / Extensions**

**ZG-NMSA-1** Short Shaft Extension



**AV8-25** Shaft Extension. For damper operating shafts.  
Approx. 9.8" [170 mm] extension for shafts  
5/16" to 1" [8 to 10 mm].



The shaft adaptors listed below may be used with NM actuators.  
For more information see page 410.

**ZG-JSA-1 ZG-JSA-2 ZG-JSA-3**

**Mounting Brackets**

The mounting brackets listed below may be used with NM actuators.  
For more information see page 405.

**ZG-103 ZG-104**

**Housings**

The housings listed below may be used with NM actuators.  
For more information see pages 411 and page 372.

**ZS-100 ZS-150 ZS-T**

**Miscellaneous**

**TF-CC US** Conduit Connector for AFB, AFX / NFB, NFX / TF / GM / AM / NM / LM

**Z-NMA** NM to NMB, NMX Retrofit Mounting Bracket

M40024 - 05/10 - Subject to change. © Belimo Aircontrols (USA), Inc.

**Clamps / Position Indicators / Rotation Limiters**

<b>K-LM20</b>	Clamp. Fits shafts up to 3/4".
<b>K-LM16</b>	Standard Clamp. Fits shafts up to 5/8".
<b>K-LM12</b>	Clamp. Fits shafts up to 1/2".
<b>K-LM10</b>	Clamp. Fits shafts up to 3/8".

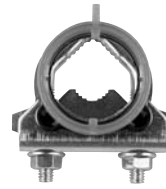
**Shaft Adaptors / Extensions**

<b>ZG-LMSA</b>	Shaft Extension
<b>ZG-LMSA-1</b>	Shaft Extension
<b>AV6-20</b>	Shaft Extension. For damper operating shafts. Approx. 6 5/8" [170 mm] extension for shafts 1/4" to 3/4" [6 to 20 mm] (must use K6-1 clamp).

**Housings**

The housings listed below may be used with LM actuators.  
For more information see pages 411 and 372.

**ZS-100    ZS-150    ZS-T**

**Miscellaneous**

<b>TF-CC US</b>	Conduit Connector for TF / GM / AM / NM / LM
<b>TF-P</b>	Anti-Rotation T-Bracket for TF / LM.

## AH/LH Accessories

### Crank arms / Ball Joints / Push Rods

**KH6** Universal Crank Arm  
(For more information see Universal Accessories).

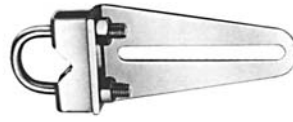

**KH8** Universal Crank Arm  
(For more information see Universal Accessories).

**KG6** Ball Joint (Zinc Plated)  
(For more information see Universal Accessories).



**KG8** Ball Joint (Galvanized)  
(For more information see Universal Accessories).



**KG10** Ball Joint (Zinc Plated)  
(For more information see Universal Accessories).



**SH8** Push Rod  
(For more information see Universal Accessories).

**SH10** Push Rod  
(For more information see Universal Accessories).

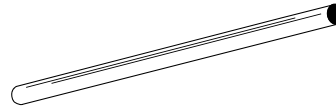

## Miscellaneous

**TF-CC US** Conduit Connector for TF / GM / AM / NM / LM

**Z-DS1** Rotary Support for Lateral Force Compensation

## LU Accessories

### Clamps / Position Indicators / Rotation Limiters

**K-LU** Spindle Clamp. Fits shafts 5/16" to 1/2".

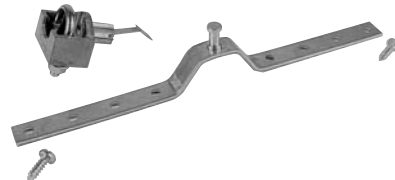

**ZDB-LU** Angle of Rotation Limiter for LU.

**Z-DS1** Rotary Support for Lateral Force Compensation

**Z-KSA** 5/16" Shaft Clevis

**Z-KSC** 3/8" Shaft Clevis

## Housings

The housings listed below may be used with LU actuators.  
For more information see pages 411 and 372.

**ZS-100**    **ZS-150**    **ZS-T**

## Miscellaneous

**TF-CC US** Conduit Connector for TF / GM / AM / NM / LM

M40024 - 05/10 - Subject to change. © Belimo Aircontrols (USA), Inc.

## Universal Crank arms

- KH6** Zinc plated steel. Slot width 1/4" (6.2mm).  
For damper shafts:  
3/8" to 11/16" dia. (10 to 18mm) or  
3/8" to 9/16" sq. (10 to 14mm).  
Uses KG6 Ball Joint.
- KH8** Zinc plated steel. Slot width 21/64" (8.2mm).  
For damper shafts:  
3/8" to 11/16" dia. (10 to 18mm) or  
3/8" to 9/16" sq. (10 to 14mm).  
Uses KG8 or KG10A Ball Joint.
- KH10** Zinc plated steel. Slot width 21/64" (8.2mm).  
For damper shafts:  
9/16" to 1.05" dia. (14 to 25mm).  
Uses KG10A Ball Joint.
- KH12** Zinc plated steel. Slot width 21/64" (8.2mm).  
For damper shafts:  
3/4" to 1" dia. (20 to 25mm).  
Uses KG10A Ball Joint.

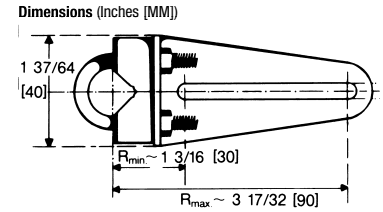
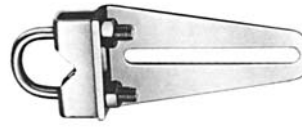

**KH10**



**KH12**

## Ball Joints

- KG6** For KH6 Universal Crank Arm. Zinc plated steel.  
For 5/16" dia. rod (8mm).  
The KG6 ball joint is only recommended  
up to 70 in-lbs. (8Nm)
- KG8** For KH8 Universal Crank Arm  
Galvanized steel. 90° angle.  
For 5/16" dia. rod (8mm).
- KG10A** Zinc Plated Steel  
Used with following crank arms:  
KH8 = 5/16" (8mm)

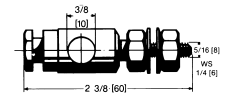
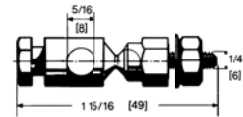

## Push Rods

- SH8** For KG6 and KG8 Ball Joints. 36" length, 5/16" dia.
- SH10** For KG10 Ball Joints. 36" length, 3/8" dia.

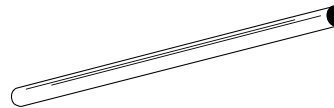

## Damper Clips

- ZG-DC1** Mounts to Damper Blades – 3.5"
- ZG-DC2** Mounts to Damper Blades – 6"

The ZG-DC1 and ZG-DC2 damper clips are designed to mount to damper blades and work as crank arms in damper linkage applications. The ZG-DC1 is designed to be used in applications where the actuator is located in front of the damper. The ZG-DC2 is designed to be used when the actuator is located above or below the damper.

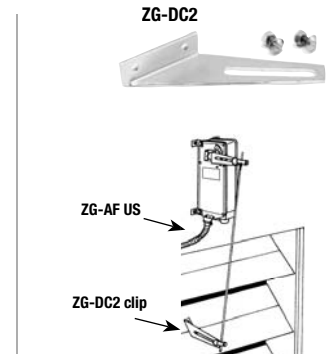
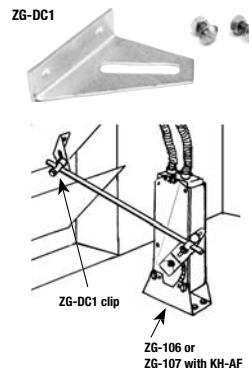

# ZG-102 Multiple Actuator Mounting Bracket

For AFB, AFX, AF and GM Series Actuators



## Application

The ZG-102 multiple actuator mounting bracket is designed for cases where it is necessary to mount two actuators to one shaft to provide extra torque.

The dual mounting bracket is typically used with the AFB, AFX, AF and GM series actuators. This is due to the fact that each of these series are the highest torque range available.

Figures A and B demonstrates two different mounting configurations using the ZG-102 mounting bracket.

## Accessory

AV10 - 25 Universal shaft extension

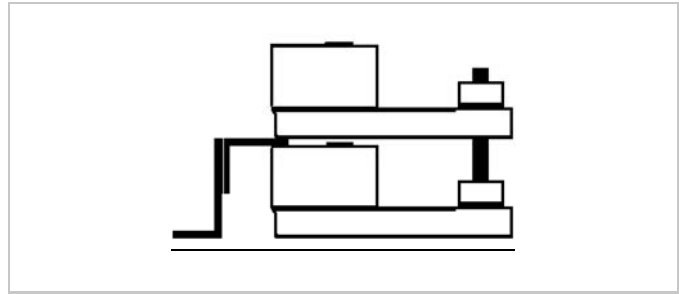

**FIGURE A**

The major advantage with this method is it requires less mounting area. The manual override, if available, cannot be used in this configuration.

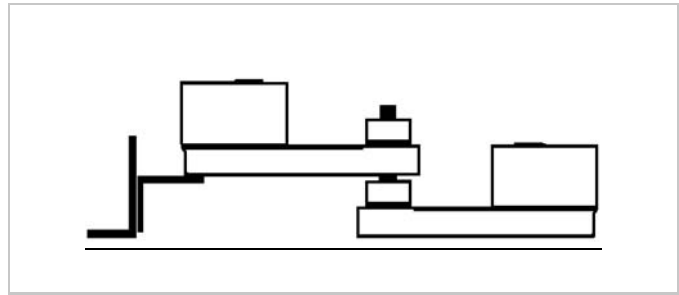

**FIGURE B**

The major advantages are that a shorter shaft is required and a lower profile is achieved.

## Dimensions (Inches [mm])

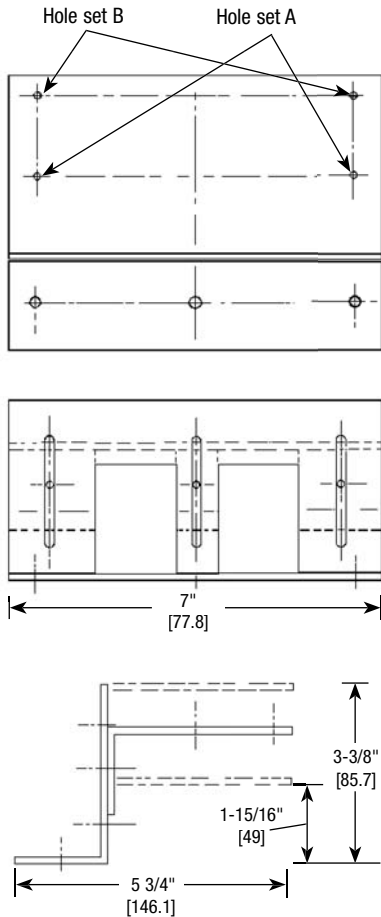

Material	12 GA Galvanized
Weight	1.8 lbs.

## OTHER CRANK ARM ADAPTOR KITS AND UNIVERSAL MOUNTING BRACKETS

KIT	MOUNTING BRACKET*	ACTUATOR USED WITH
ZG-AFB	NA	AFB, AFX, NFB, NFX
ZG-AFB118	ZG-118	AFB, AFX, NFB, NFX
ZG-AF108	ZG-108 (Included)	AF
ZG-AF US	ZG-100, ZG-101	AF
ZG-LF112	ZG-112 (Included)	LF
ZG-LF2	NA	LF
ZG-LFC114	NA	LF
ZG-ECON1	ZG-112 (Included)	LF
ZG-ECON2	ZG-112 (Included)	LF
ZG-TF112	ZG-113 (Included)	TF
ZG-TF2	NA	TF
ZG-GMA	ZG-101, ZG-101, ZG-103, ZG-104	GM
ZG-NMA	ZG-101, ZG-101, ZG-103, ZG-104	NM, AM
NA	ZG-106	AF
NA	ZG-107	AF

\*Unless otherwise noted, mounting brackets are not included in crank arm adaptor kits.

M40024 - 05/10 - Subject to change. © Belimo Aircontrols (USA), Inc.

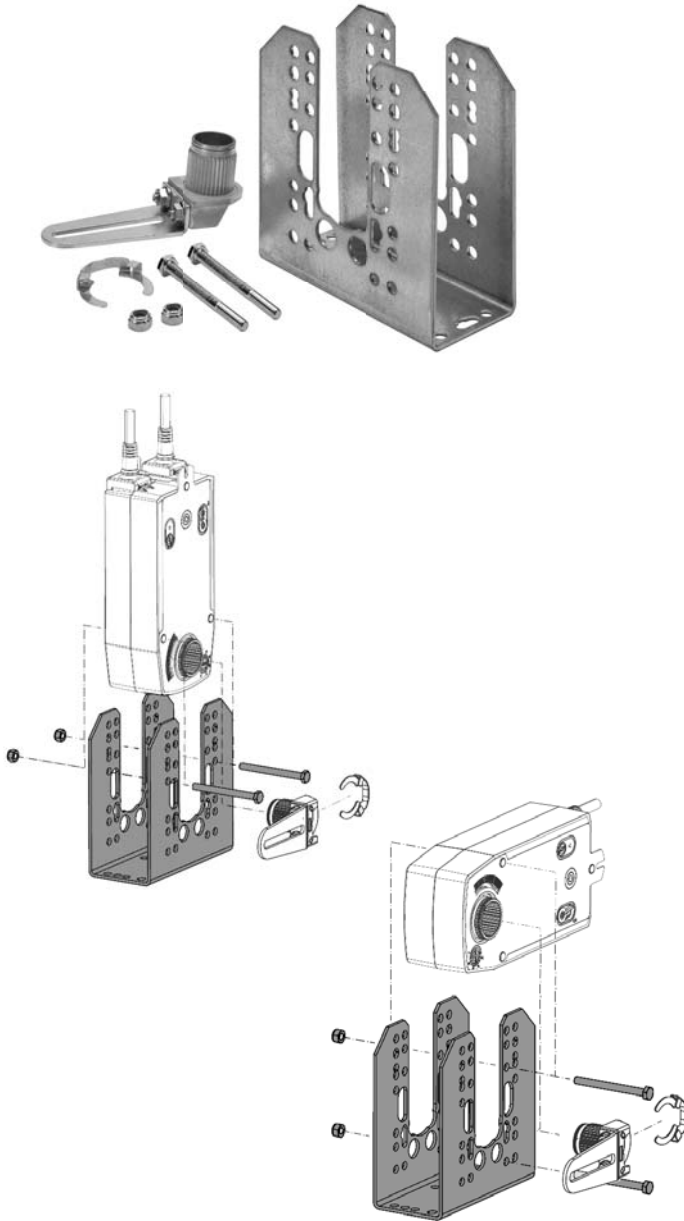

### Application

The ZG-AFB118 Crank Arm Adaptor Kit is designed for applications where the actuator cannot be mounted directly to the damper shaft. It may be used for outside or inside the duct mounting.

### The ZG-AFB118 Crank Arm Adaptor Kit includes:

- 1 ZG-118 Mounting Bracket
- 1 KH-AFB Crank Arm with Retaining Clip
- 2 Bolts with Nuts

**NOTE:** May require crank arm and ball joints

The ZG-118 is provided with hole patterns to mount the AFB, AFX, NFB and NFX actuators in either a horizontal or vertical position to meet space requirements. The KH-AFB crank arm is required to fully convert the AFB, AFX, NFB or NFX for crank arm operation.

The ZG-118 is designed to mount the AFB, AFX, NFB and NFX actuators in the same mounting locations as common foot mounted, crank arm style actuators. Hole patterns in the base match common Honeywell™, Siebe™ (Barber Coleman™) and Johnson Controls™ actuators for easy retrofit.

### USE WHEN REPLACING THESE ACTUATORS

Honeywell	M91...	M955...	M975...
	M945...	M965...	M8...
Johnson	M110...	M130...	M150...
	M120...	M140...	
Barber Coleman	MA3...	MA4...	MA5...

### Dimensions (Inches [mm])

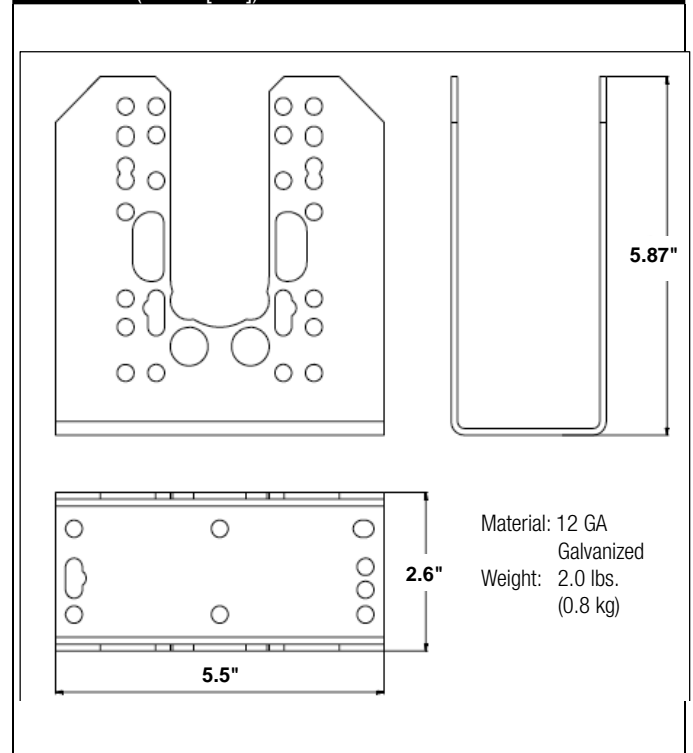

### OTHER CRANK ARM ADAPTOR KITS AND UNIVERSAL MOUNTING BRACKETS

KIT	MOUNTING BRACKET*	ACTUATOR USED WITH
ZG-AFB	NA	AFB, AFX, NFB, NFX
ZG-AFB118	ZG-118	AFB, AFX, NFB, NFX
ZG-AF108	ZG-108 (Included)	AF
ZG-AF US	ZG-100, ZG-101	AF
ZG-LF112	ZG-112 (Included)	LF
ZG-LF2	NA	LF
ZG-LFC114	NA	LF
ZG-ECON1	ZG-112 (Included)	LF
ZG-ECON2	ZG-112 (Included)	LF
ZG-TF112	ZG-113 (Included)	TF
ZG-TF2	NA	TF
ZG-GMA	ZG-101, ZG-101, ZG-103, ZG-104	GM
ZG-NMA	ZG-101, ZG-101, ZG-103, ZG-104	NM, AM
NA	ZG-106	AF
NA	ZG-107	AF

\*Unless otherwise noted, mounting brackets are not included in crank arm adaptor kits.



# ZG-AFB118 Crank Arm Adaptor Kit

## Mounting Positions for Typical Replacements

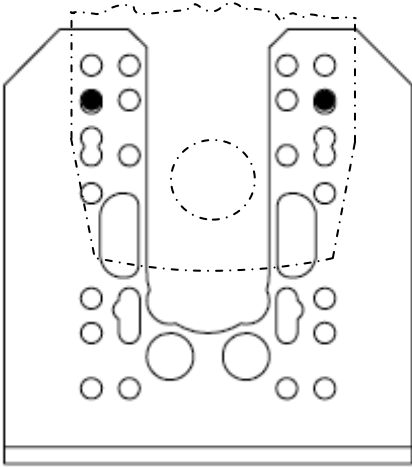

Barber Colman™ MA Type - Vertical

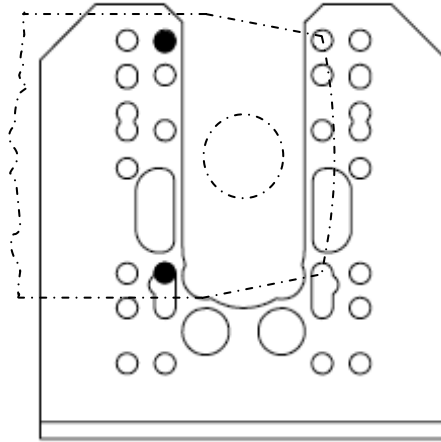

Barber Colman™ MA Type - Horizontal (left)

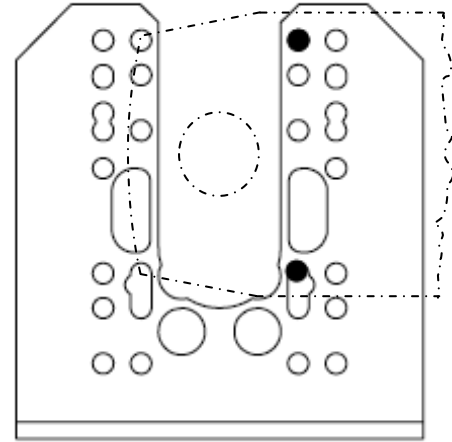

Barber Colman™ MA Type - Horizontal (right)

*Black holes represent correct bolt locations*

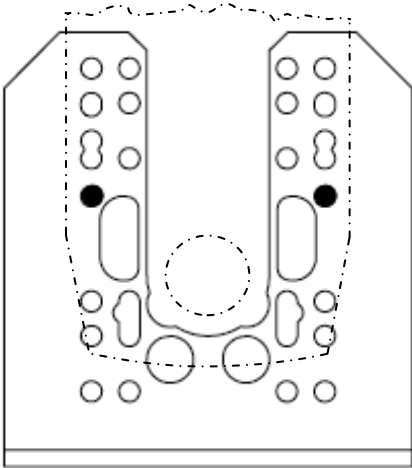

Honeywell™ Mod. IV Type - Vertical

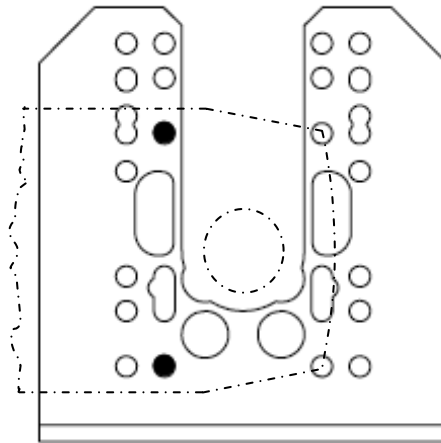

Honeywell™ Mod. IV Type - Horizontal (left)

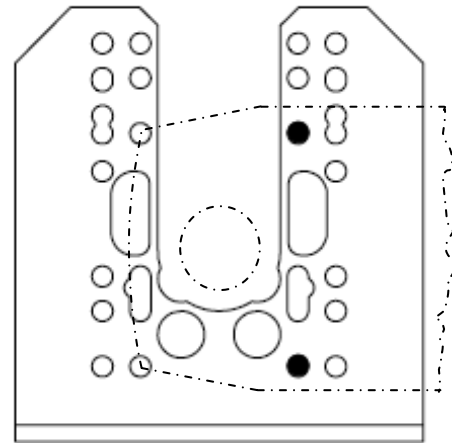

Honeywell™ Mod. IV Type - Horizontal (right)

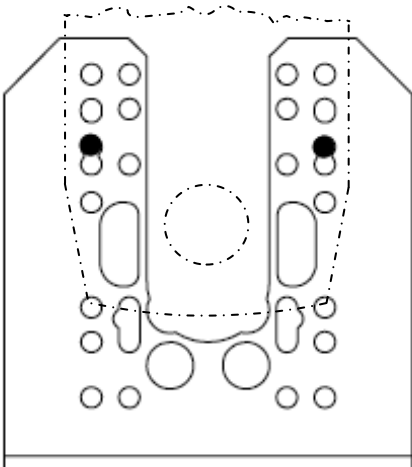

Johnson Controls™ 100 Series Type and  
Honeywell™ Mod. III Type - Vertical

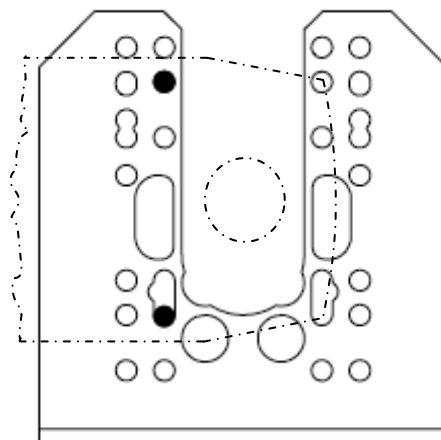

Johnson Controls™ 100 Series Type and  
Honeywell™ Mod. III Type - Horizontal (left)

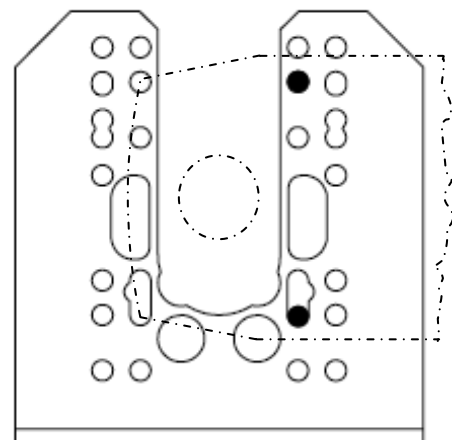

Johnson Controls™ 100 Series Type and  
Honeywell™ Mod. III Type - Horizontal (right)

M40024 - 05/10 - Subject to change. © Belimo Aircontrols (USA), Inc.

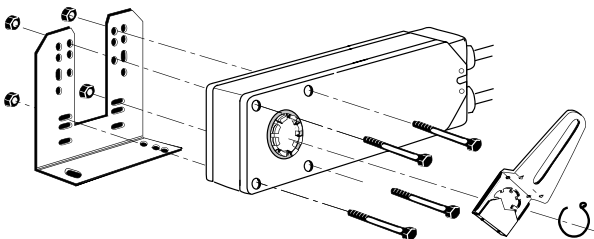
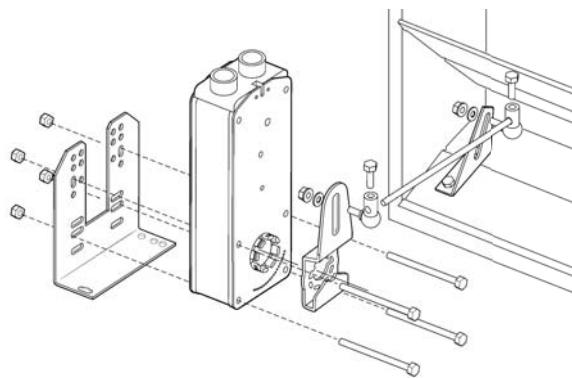
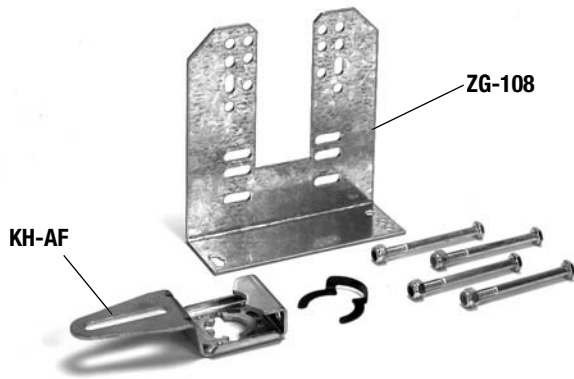

## Application

The ZG-AF108 Crank Arm Adaptor Kit is designed for applications where the actuator cannot be mounted directly to the damper shaft. It may be used for outside or inside the duct mounting.

### The ZG-AF108 Crank Arm Adaptor Kit includes:

- 1 ZG-108 Mounting Bracket
- 1 KH-AF Crank Arm with Retaining Ring
- 4 Bolts with Nuts

**NOTE:** May require crank arm and ball joints

The ZG-108 is provided with hole patterns to mount the AF series actuators in either a horizontal or vertical position to meet space requirements.

The ZG-108 Mounting Bracket is designed to mount the AF series actuator in the same mounting locations as common foot mounted, crank arm style actuators. Hole patterns in the base match common Honeywell™, Siebe™ (Barber Coleman™), and Johnson Controls™ actuators for easy retrofit.

### USE WHEN REPLACING THESE ACTUATORS

Honeywell	M91...	M955...	M975...
	M945...	M965...	M8...
Johnson	M110...	M130...	M150...
	M120...	M140...	
Barber Coleman	MA3...	MA4...	MA5...

### Dimensions (Inches [mm])

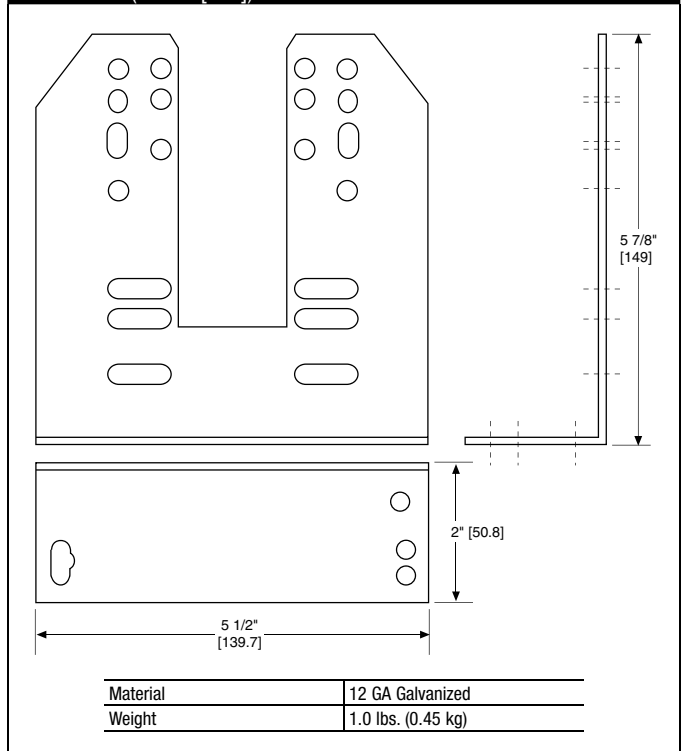

### OTHER CRANK ARM ADAPTOR KITS AND UNIVERSAL MOUNTING BRACKETS

KIT	MOUNTING BRACKET*	ACTUATOR USED WITH
ZG-AFB	NA	AFB, AFX, NFB, NFX
ZG-AFB118	ZG-118	AFB, AFX, NFB, NFX
ZG-AF108	ZG-108 (Included)	AF
ZG-AF US	ZG-100, ZG-101	AF
ZG-LF112	ZG-112 (Included)	LF
ZG-LF2	NA	LF
ZG-LFC114	NA	LF
ZG-ECON1	ZG-112 (Included)	LF
ZG-ECON2	ZG-112 (Included)	LF
ZG-TF112	ZG-113 (Included)	TF
ZG-TF2	NA	TF
ZG-GMA	ZG-101, ZG-101, ZG-103, ZG-104	GM
ZG-NMA	ZG-101, ZG-101, ZG-103, ZG-104	NM, AM
NA	ZG-106	AF
NA	ZG-107	AF

\*Unless otherwise noted, mounting brackets are not included in crank arm adaptor kits.

# ZG-AF108 Crank Arm Adaptor Kit

Mounting Positions for Typical Replacements

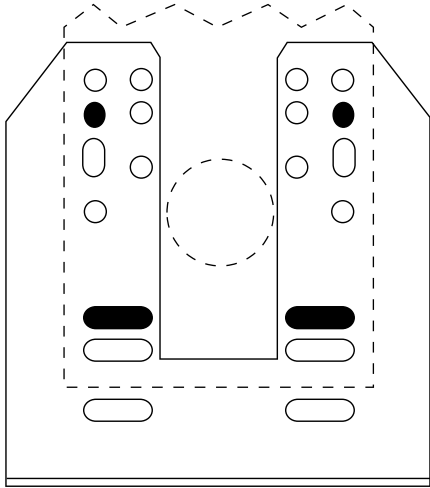

Barber Colman™ MA Type - Vertical

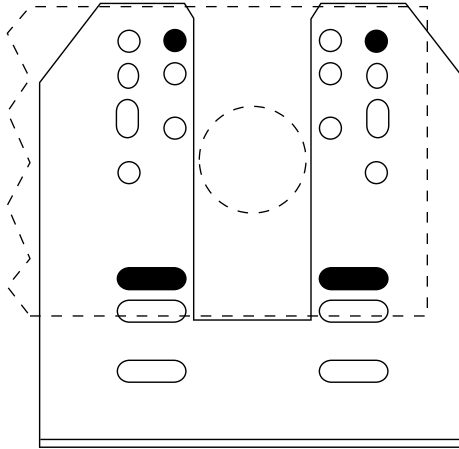

Barber Colman™ MA Type - Horizontal (left)

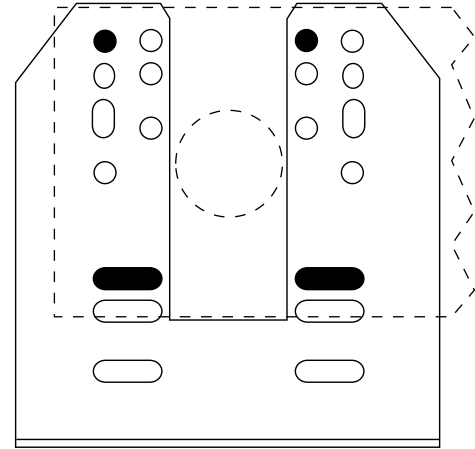

Barber Colman™ MA Type - Horizontal (right)

*Black holes represent correct bolt locations.*

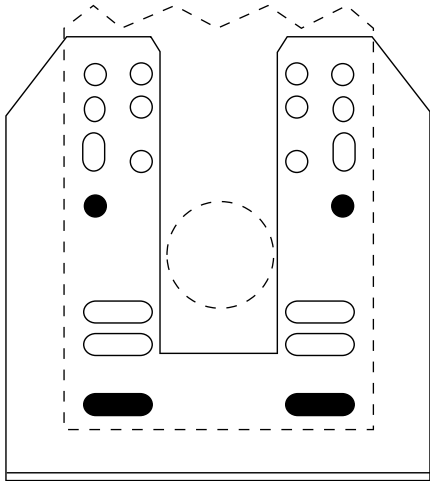

Honeywell™ Mod. IV Type - Vertical

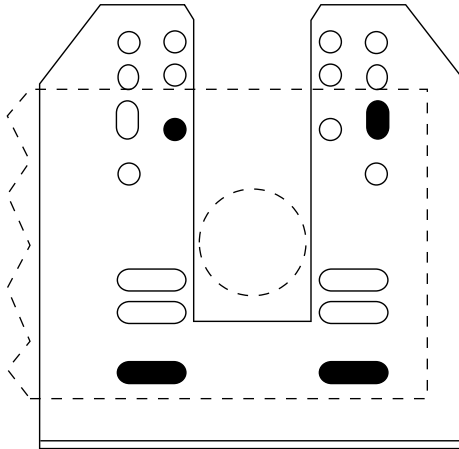

Honeywell™ Mod. IV Type - Horizontal (left)

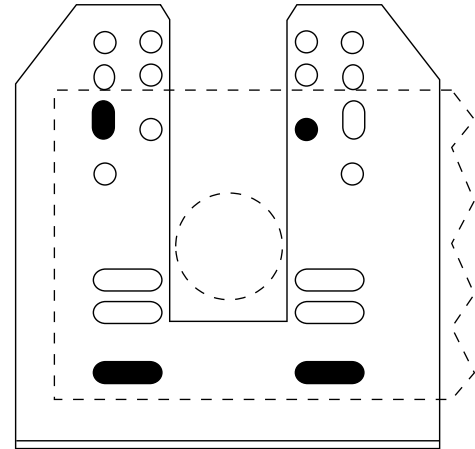

Honeywell™ Mod. IV Type - Horizontal (right)

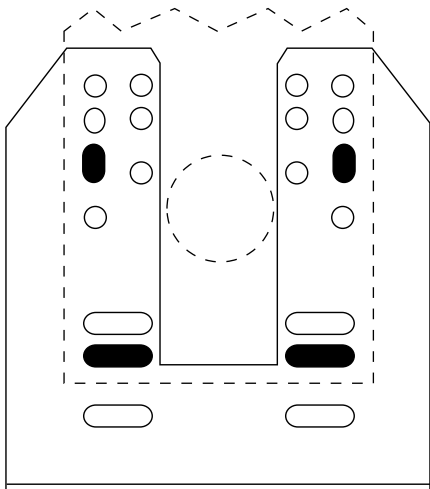

Johnson Control™ 100 Series Type  
and Honeywell™ Mod. III Type  
Vertical

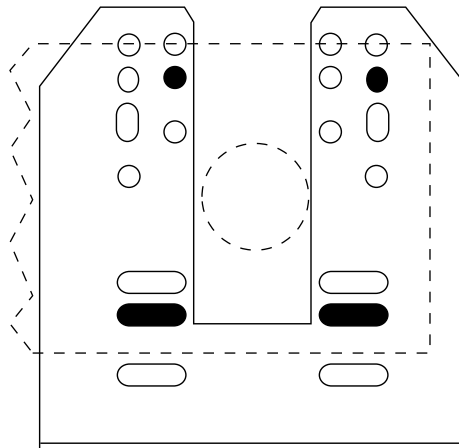

Johnson Control™ 100 Series Type  
and Honeywell™ Mod. III Type  
Horizontal (left)

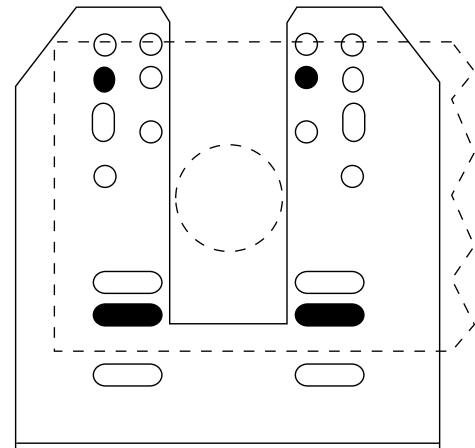

Johnson Control™ 100 Series Type  
and Honeywell™ Mod. III Type  
Horizontal (right)

M40024 - 05/10 - Subject to change. © Belimo Aircontrols (USA), Inc.

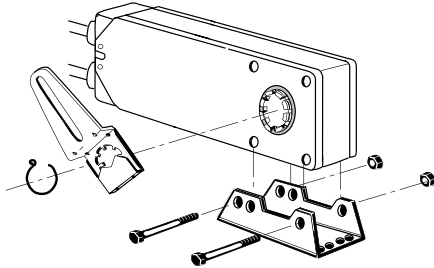
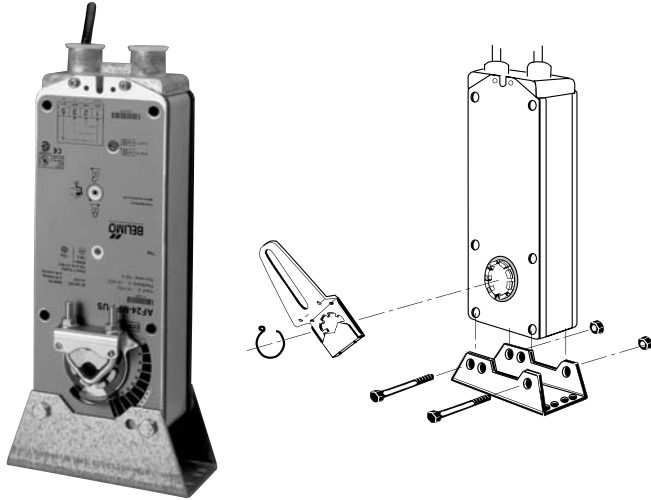

## Application

The ZG-106 and ZG-107 Universal Mounting Brackets are designed for applications where the actuator cannot be mounted directly to the damper shaft. They may be used for outside or inside the duct mounting.

The ZG-106 and ZG-107 is provided with hole patterns to mount the AF series actuators in either a horizontal or vertical position to meet space requirements.

The KH-AF crank arm is required to fully convert the AF for crank arm operation.

The ZG-106 and ZG-107 are designed to mount the AF series actuators in the same mounting locations as common foot mounted, crank arm style actuators. Hole patterns in the base match common Honeywell™, Siebe™ (Barber Coleman™), and Johnson Controls™ actuators for easy retrofit.

The ZG-106 is designed to place the KH-AF crank arm in the same relative position as the Honeywell™ Mod IV actuators. The ZG-107 is designed to place the crank arm in the same relative position as the Honeywell™ Mod III actuators.

### USE THE ZG-106 WHEN REPLACING THESE ACTUATORS

Honeywell	Mod IV	M91...	M945...		
	M955...	M965...	M975...	M8...	

### USE THE ZG-107 WHEN REPLACING THESE ACTUATORS

Honeywell	Mod III
-----------	---------

### OTHER CRANK ARM ADAPTOR KITS AND UNIVERSAL MOUNTING BRACKETS

KIT	MOUNTING BRACKET*	ACTUATOR USED WITH
ZG-AFB	NA	AFB, AFX, NFB, NFX
ZG-AFB118	ZG-118	AFB, AFX, NFB, NFX
ZG-AF108	ZG-108 (Included)	AF
ZG-AF US	ZG-100, ZG-101	AF
ZG-LF112	ZG-112 (Included)	LF
ZG-LF2	NA	LF
ZG-LFC114	NA	LF
ZG-ECON1	ZG-112 (Included)	LF
ZG-ECON2	ZG-112 (Included)	LF
ZG-TF112	ZG-113 (Included)	TF
ZG-TF2	NA	TF
ZG-GMA	ZG-101, ZG-101, ZG-103, ZG-104	GM
ZG-NMA	ZG-101, ZG-101, ZG-103, ZG-104	NM, AM
NA	ZG-106	AF
NA	ZG-107	AF

\*Unless otherwise noted, mounting brackets are not included in crank arm adaptor kits.

### Dimensions (Inches [mm])

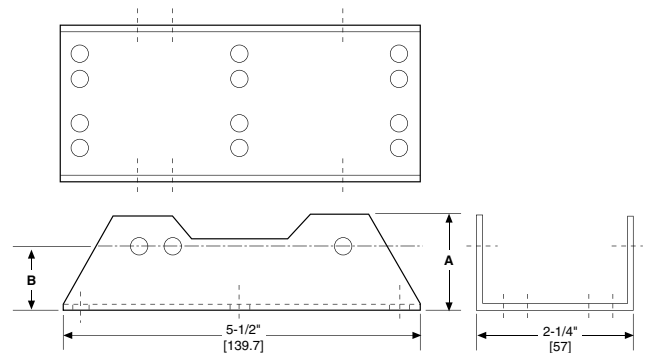

	A	B
ZG-106	1.50"	1.02"
ZG-107	2.25"	1.77"

Material	12 GA Galvanized	
Weight	ZG-106	0.7 lbs.
	ZG-107	0.9 lbs.

# ZG-AFB Crank Arm Adaptor Kit

For AFB, AFX, NFB and NFX Series Actuators



## ZG-AFB

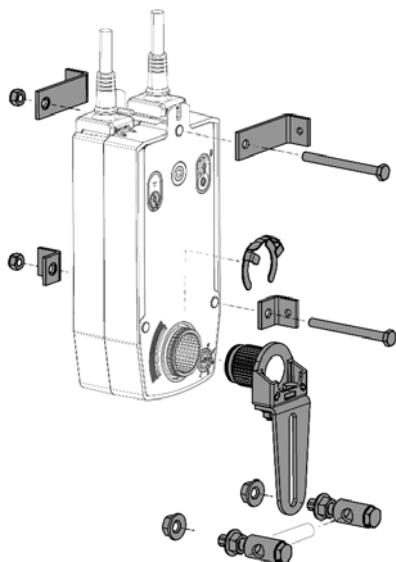
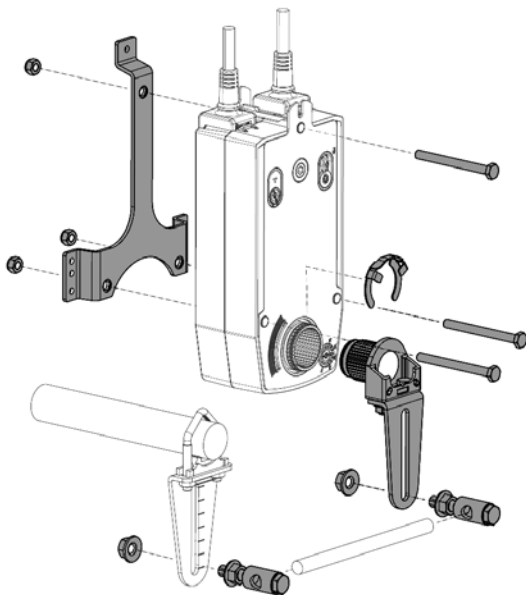
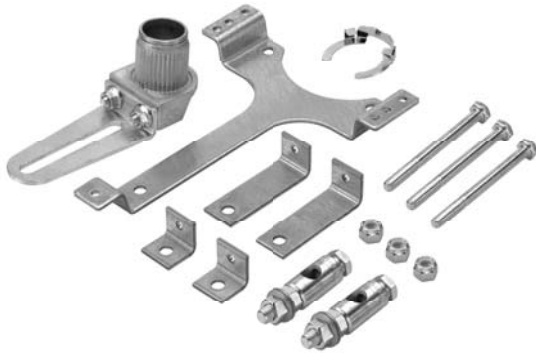

## Application

The ZG-AFB Crank Arm Adaptor Kit is designed for applications where the actuator cannot be mounted directly to the damper shaft.

### The ZG-AFB Crank Arm Adaptor Kit includes:

- 1 KH-AFB Crank Arm with Retaining Clip
- 1 "T" Bracket
- 4 Mounting Feet
- 3 Bolts with Nuts
- 2 KG10A Ball Joints

The following Universal Mounting Brackets are needed to fully convert to crank arm operation:

- ZG-100**
- ZG-101**

The ZG-100 and ZG-101 Universal Mounting Brackets are designed for applications where the actuator cannot be mounted directly to the shaft, and no proper mounting surface is available. It may be used for outside or inside the duct mounting, fastened to the ductwork or directly to the damper assembly. It may also be used to mount to other surfaces rather than the duct.

The ZG-100 and ZG-101 are provided with pre-punched hole patterns for the AM, SM, GM, AF, AFB(X) and NFB(X) series actuators. The ZG-100 hole pattern layout allows mounting these actuators in three different, mounting orientations. The ZG-101 hole pattern layout allows mounting these actuators in two different, mounting orientations. The ZG-100 and ZG-101 may also be field drilled for special or more exact mounting of linkage components.

For technical data and dimensions on ZG-100 and ZG-101 Universal Mounting Brackets, see page 405.

### OTHER CRANK ARM ADAPTOR KITS AND UNIVERSAL MOUNTING BRACKETS

KIT	MOUNTING BRACKET*	ACTUATOR USED WITH
ZG-AFB	NA	AFB, AFX, NFB, NFX
ZG-AFB118	ZG-118	AFB, AFX, NFB, NFX
ZG-AF108	ZG-108 (Included)	AF
ZG-AF US	ZG-100, ZG-101	AF
ZG-LF112	ZG-112 (Included)	LF
ZG-LF2	NA	LF
ZG-LFC114	NA	LF
ZG-ECON1	ZG-112 (Included)	LF
ZG-ECON2	ZG-112 (Included)	LF
ZG-TF112	ZG-113 (Included)	TF
ZG-TF2	NA	TF
ZG-GMA	ZG-101, ZG-101, ZG-103, ZG-104	GM
ZG-NMA	ZG-101, ZG-101, ZG-103, ZG-104	NM, AM
NA	ZG-106	AF
NA	ZG-107	AF

\*Unless otherwise noted, mounting brackets are not included in crank arm adaptor kits.

M40024 - 05/10 - Subject to change. © Belimo Aircontrols (USA), Inc.

### ZG-AF US

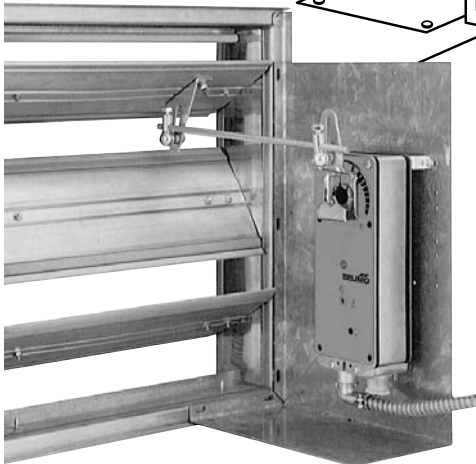
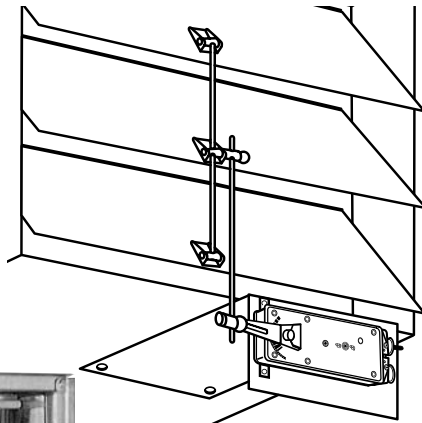
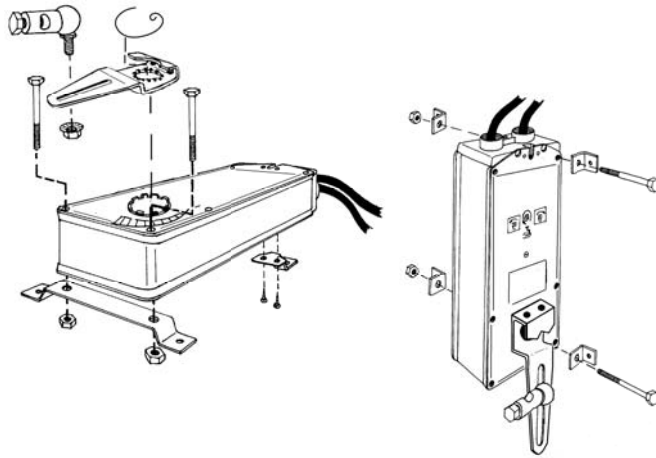
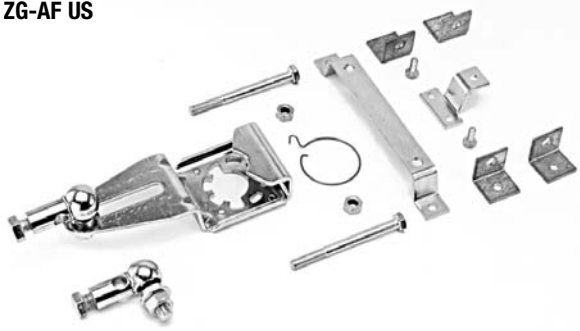

### Application

The ZG-AF US Crank Arm Adaptor Kit is designed for applications where the actuator cannot be mounted directly to the damper shaft.

#### The ZG-AF US Crank Arm Adaptor Kit includes:

- 1 KH-AF Crank Arm with Retaining Ring
- 2 Standoff Brackets
- 4 Mounting Feet
- 2 Bolts with Nuts
- 2 Self-Tapping Screws
- 2 KG8 Ball Joints

The following Universal Mounting Brackets are needed to fully convert to crank arm operation:

- ZG-100**
- ZG-101**

The ZG-100 and ZG-101 Universal Mounting Brackets are designed for applications where the actuator cannot be mounted directly to the shaft, and no proper mounting surface is available. It may be used for outside or inside the duct mounting, fastened to the ductwork or directly to the damper assembly. It may also be used to mount to other surfaces rather than the duct.

The ZG-100 and ZG-101 are provided with pre-punched hole patterns for the AM, SM, GM, AF, AFB(X) and NFB(X) series actuators. The ZG-100 hole pattern layout allows mounting these actuators in three different, mounting orientations. The ZG-101 hole pattern layout allows mounting these actuators in two different, mounting orientations. The ZG-100 and ZG-101 may also be field drilled for special or more exact mounting of linkage components.

For technical data and dimensions on ZG-100 and ZG-101 Universal Mounting Brackets, see page 405.

### OTHER CRANK ARM ADAPTOR KITS AND UNIVERSAL MOUNTING BRACKETS

KIT	MOUNTING BRACKET*	ACTUATOR USED WITH
ZG-AFB	NA	AFB, AFX, NFB, NFX
ZG-AFB118	ZG-118	AFB, AFX, NFB, NFX
ZG-AF108	ZG-108 (Included)	AF
ZG-AF US	ZG-100, ZG-101	AF
ZG-LF112	ZG-112 (Included)	LF
ZG-LF2	NA	LF
ZG-LFC114	NA	LF
ZG-ECON1	ZG-112 (Included)	LF
ZG-ECON2	ZG-112 (Included)	LF
ZG-TF112	ZG-113 (Included)	TF
ZG-TF2	NA	TF
ZG-GMA	ZG-101, ZG-101, ZG-103, ZG-104	GM
ZG-NMA	ZG-101, ZG-101, ZG-103, ZG-104	NM, AM
NA	ZG-106	AF
NA	ZG-107	AF

\*Unless otherwise noted, mounting brackets are not included in crank arm adaptor kits.

# ZG-GMA Crank Arm Adaptor Kit

For GM Series Actuators

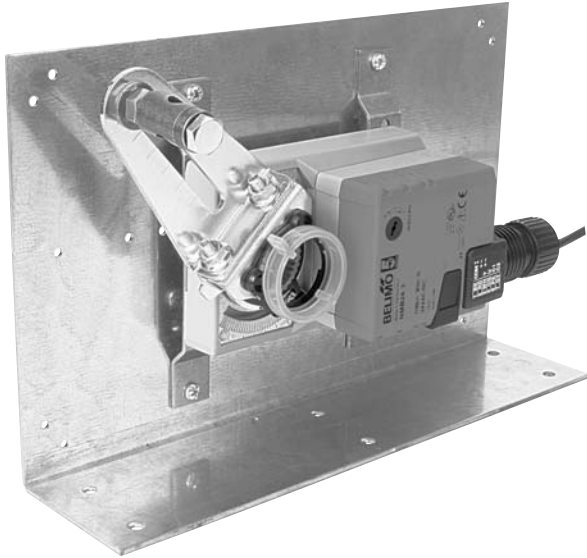

## Application

The ZG-GMA Crank Arm Adaptor Kit is designed for applications where the actuator cannot be mounted directly to the damper shaft.

### The ZG-GMA Crank Arm Adaptor Kit includes:

- 1 AH-25 Crank Arm
- 2 KG10 Ball Joints
- 2 Mounting Brackets
- 1 Spacer
- Mounting Hardware

The following Universal Mounting Brackets are needed to fully convert to crank arm operation:

- ZG-100**
- ZG-101**
- ZG-103**
- ZG-104**

The ZG-100, ZG-101, ZG-103, and ZG-104 Universal Mounting Brackets are designed for applications where the actuator cannot be mounted directly to the shaft, and no proper mounting surface is available. It may be used for outside or inside the duct mounting, fastened to the ductwork or directly to the damper assembly. It may also be used to mount to other surfaces rather than the duct.

The ZG-100, ZG-101, ZG-103, ZG-104 are provided with pre-punched hole patterns for the NM, AM, SM, GM, AFB(X), NFB(X), and AF series actuators. The ZG-100 hole pattern layout allows mounting these actuators in three different, mounting orientations. The ZG-101, ZG-103, and ZG-104 hole pattern layout allows mounting these actuators in two different, mounting orientations. The ZG-100 and ZG-101 may also be field drilled for special or more exact mounting of linkage components.

For technical data and dimensions on ZG-100 , ZG-101, ZG-103, and ZG-104 Universal Mounting Brackets, see page 405.

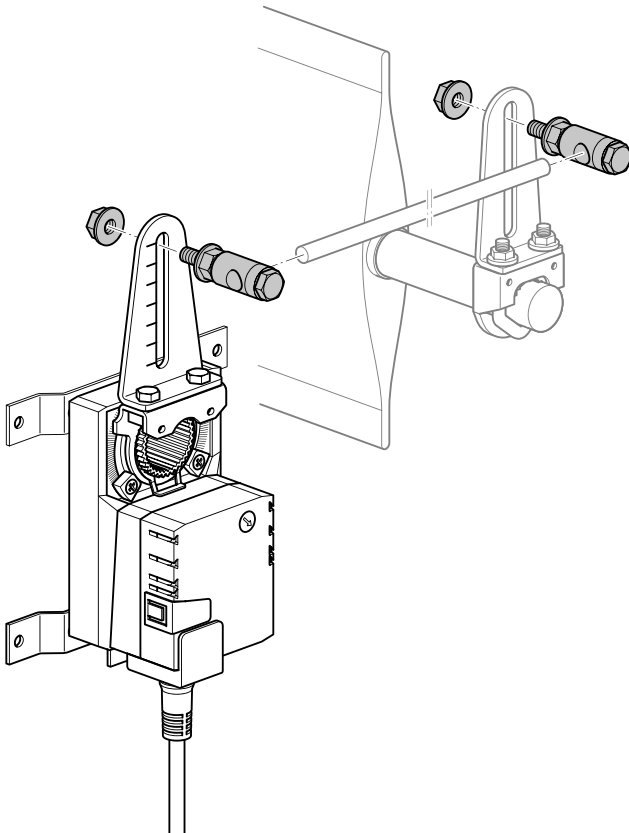

### OTHER CRANK ARM ADAPTOR KITS AND UNIVERSAL MOUNTING BRACKETS

KIT	MOUNTING BRACKET*	ACTUATOR USED WITH
ZG-AFB	NA	AFB, AFX, NFB, NFX
ZG-AFB118	ZG-118	AFB, AFX, NFB, NFX
ZG-AF108	ZG-108 (Included)	AF
ZG-AF US	ZG-100, ZG-101	AF
ZG-LF112	ZG-112 (Included)	LF
ZG-LF2	NA	LF
ZG-LFC114	NA	LF
ZG-ECON1	ZG-112 (Included)	LF
ZG-ECON2	ZG-112 (Included)	LF
ZG-TF112	ZG-113 (Included)	TF
ZG-TF2	NA	TF
ZG-GMA	ZG-101, ZG-101, ZG-103, ZG-104	GM
ZG-NMA	ZG-101, ZG-101, ZG-103, ZG-104	NM, AM
NA	ZG-106	AF
NA	ZG-107	AF
NA	ZG-107	AF

\*Unless otherwise noted, mounting brackets are not included in crank arm adaptor kits.

M40024 - 05/10 - Subject to change. © Belimo Aircontrols (USA), Inc.

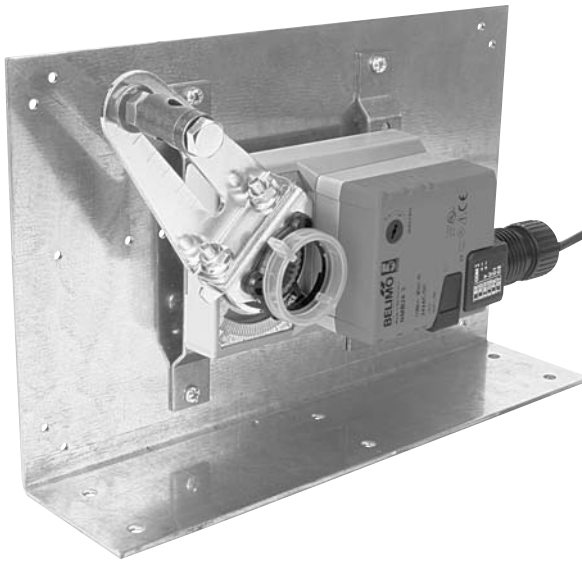

## Application

The ZG-NMA Crank arm Adaptor Kit is designed for applications where the actuator cannot be mounted directly to the damper shaft.

### The ZG-NMA Crank Arm Adaptor Kit includes:

- 1 Crank Arm
- 2 KG10 Ball Joints
- 2 Mounting Brackets
- 1 Spacer
- Mounting Hardware

The following Universal Mounting Brackets are needed to fully convert to crank arm operation:

- ZG-100**
- ZG-101**
- ZG-103**
- ZG-104**

The ZG-100, ZG-101, ZG-103, and ZG-104 Universal Mounting Brackets are designed for applications where the actuator cannot be mounted directly to the shaft, and no proper mounting surface is available. It may be used for outside or inside the duct mounting, fastened to the ductwork or directly to the damper assembly. It may also be used to mount to other surfaces rather than the duct.

The ZG-100, ZG-101, ZG-103, ZG-104 are provided with pre-punched hole patterns for the NM, AM, SM, GM, AFB(X), NFB(X), and AF series actuators. The ZG-100 hole pattern layout allows mounting these actuators in three different, mounting orientations. The ZG-101, ZG-103, and ZG-104 hole pattern layout allows mounting these actuators in two different, mounting orientations. The ZG-100 and ZG-101 may also be field drilled for special or more exact mounting of linkage components.

For technical data and dimensions on ZG-100, ZG-101, ZG-103, and ZG-104 Universal Mounting Brackets, see page 405.

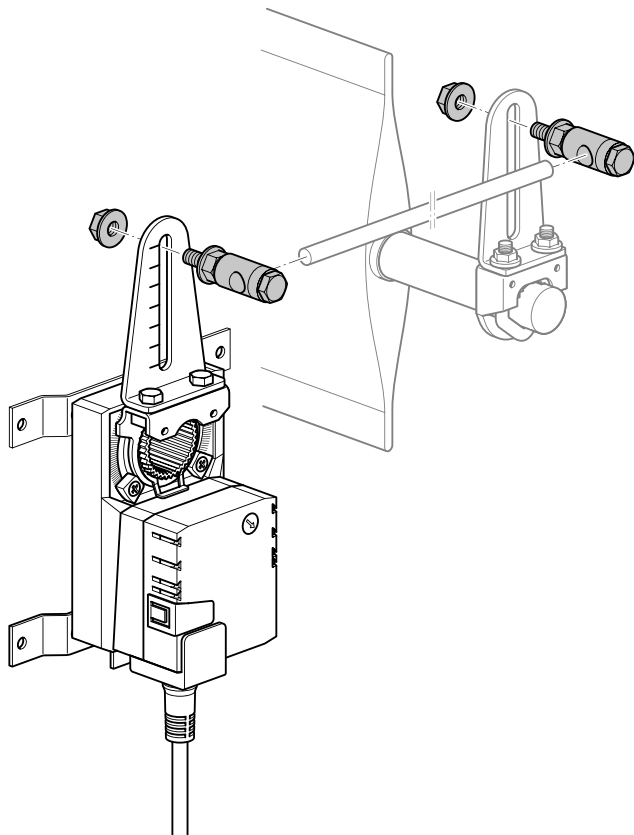

M40024 - 05/10 - Subject to change. © Belimo Aircontrols (USA), Inc.

### OTHER CRANK ARM ADAPTOR KITS AND UNIVERSAL MOUNTING BRACKETS

KIT	MOUNTING BRACKET*	ACTUATOR USED WITH
ZG-AFB	NA	AFB, AFX, NFB, NFX
ZG-AFB118	ZG-118	AFB, AFX, NFB, NFX
ZG-AF108	ZG-108 (Included)	AF
ZG-AF US	ZG-100, ZG-101	AF
ZG-LF112	ZG-112 (Included)	LF
ZG-LF2	NA	LF
ZG-LFC114	NA	LF
ZG-ECON1	ZG-112 (Included)	LF
ZG-ECON2	ZG-112 (Included)	LF
ZG-TF112	ZG-113 (Included)	TF
ZG-TF2	NA	TF
ZG-GMA	ZG-101, ZG-101, ZG-103, ZG-104	GM
ZG-NMA	ZG-101, ZG-101, ZG-103, ZG-104	NM, AM
NA	ZG-106	AF
NA	ZG-107	AF
NA	ZG-107	AF

\*Unless otherwise noted, mounting brackets are not included in crank arm adaptor kits.



# ZG-100, ZG-101, ZG-103, ZG-104 Universal Mounting Brackets

For AM, SM, GM, NFB(X), and AFB(X) Series Actuators



**ZG-100 Universal Mounting Bracket\* (Inches [mm])**

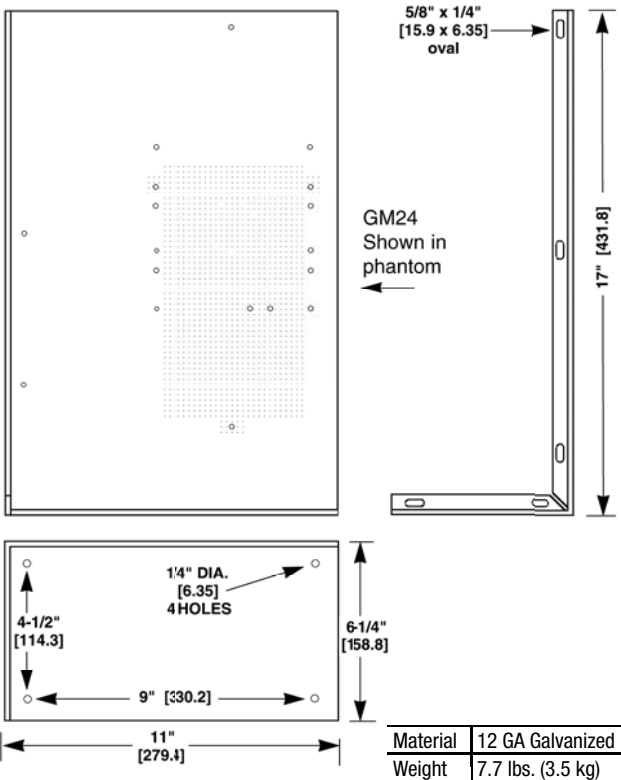

**ZG-101 Universal Mounting Bracket\* (Inches [mm])**

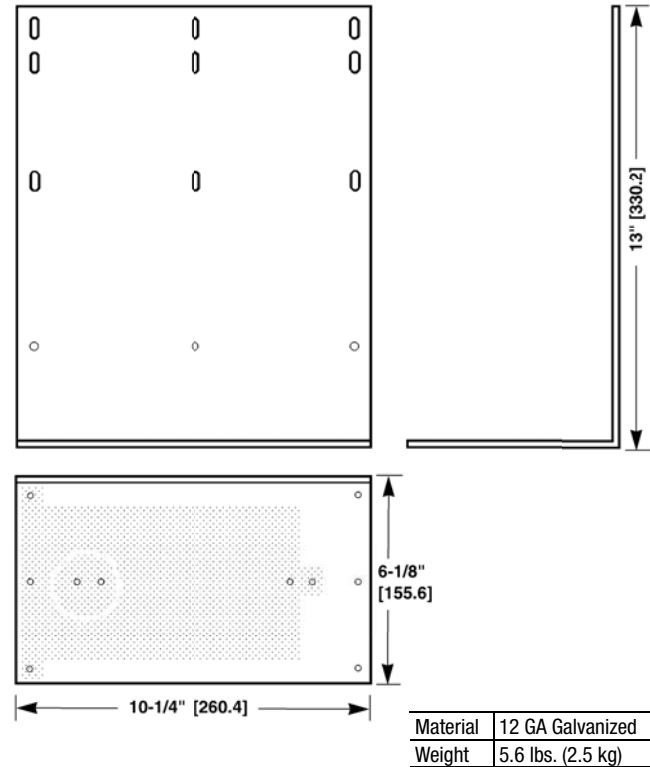

**ZG-103 Universal Mounting Bracket (Inches [mm])**

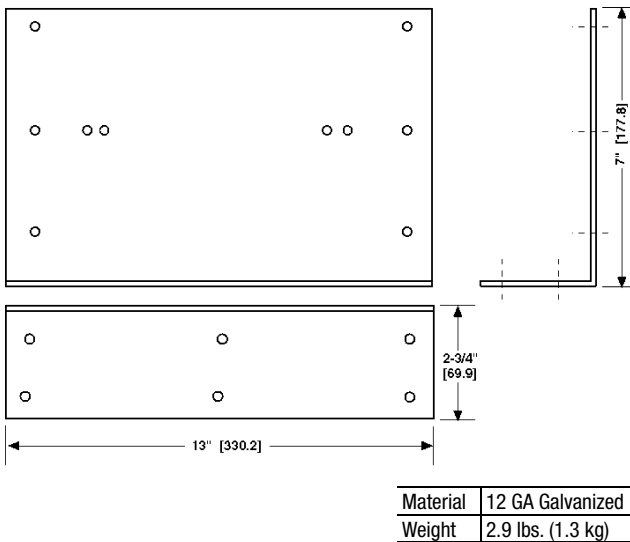

**ZG-104 Universal Mounting Bracket (Inches [mm])**

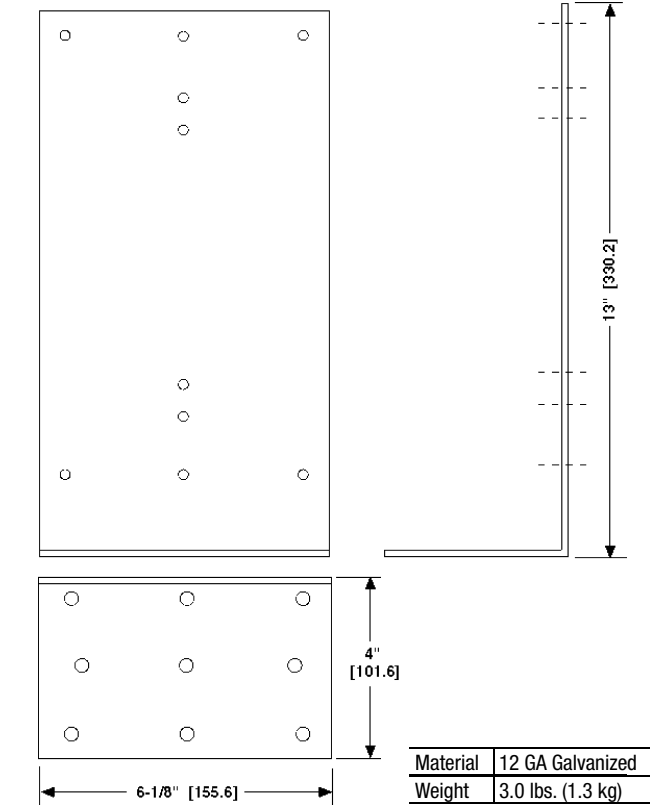

\* NOTE: ZG-AFB, ZG-AF US, ZG-GMA, or ZG-NMA Required

M40024 - 05/10 - Subject to change. © Belimo Aircontrols (USA), Inc.

## ZG-LF112 Crank Arm Adaptor Kit

For LF Series Actuators

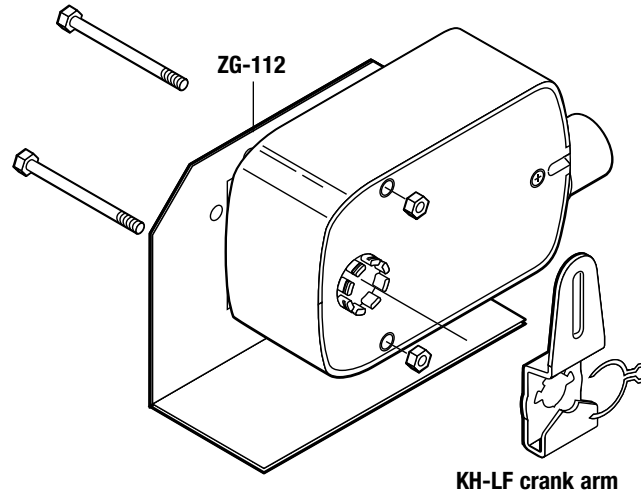

### Application

The ZG-LF112 Crank Arm Adaptor Kit is designed for applications where the actuator cannot be mounted directly to the damper shaft. It may be used for outside or inside the duct mounting.

#### The ZG-LF112 Crank Arm Adaptor Kit includes:

- 1 ZG-112 Mounting Bracket
- 1 KH-LF Crank Arm with Retaining Clip
- 2 Bolts with Nuts

**NOTE:** May require crank arm and ball joints

The ZG-112 is provided with hole patterns to mount the LF series actuators in either a horizontal or vertical position to meet space requirements.

The ZG-112 Mounting Bracket is designed to mount the NF and AF series actuator in the same mounting locations as common foot mounted, crank arm style actuators. Hole patterns in the base match common Honeywell™, Siebe™ (Barber Coleman™), and Johnson Controls™ actuators for easy retrofit.

#### USE WHEN REPLACING THESE ACTUATORS

Honeywell	M84...	M7
-----------	--------	----

## ZG-TF112 Crank Arm Adaptor Kit

For TF Series Actuators

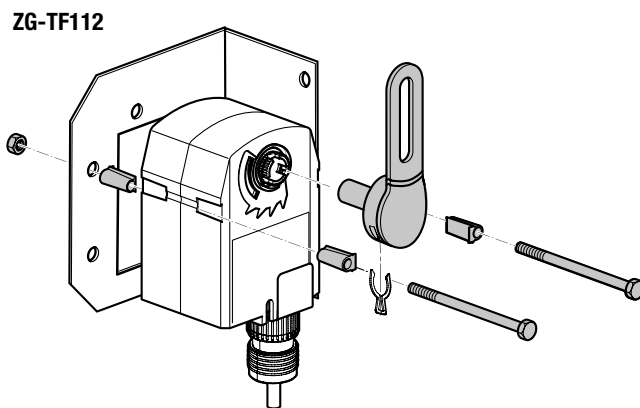

### Application

The ZG-TF112 Crank Arm Adaptor Kit is designed for applications where the actuator cannot be mounted directly to the damper shaft. It may be used for outside or inside the duct mounting.

#### The ZG-TF112 Crank Arm Adaptor Kit includes:

- 1 ZG-113 Mounting Bracket
- 1 KH-TF-1 Crank arm with Retaining Clip
- 2 Bolts with Nuts

**NOTE:** May require crank arm and ball joints

The ZG-113 is provided with hole patterns to mount the TF series actuators in either a horizontal or vertical position to meet space requirements.

The ZG-113 Mounting Bracket is designed to mount the TF series actuator in the same mounting locations as common foot mounted, crank arm style actuators. Hole patterns in the base match common Honeywell™, Siebe™ (Barber Coleman™), and Johnson Controls™ actuators for easy retrofit.

#### USE WHEN REPLACING THESE ACTUATORS

Honeywell	M84...	M7...
-----------	--------	-------

# ZG-LF2 and ZG-TF2 Crank Arm Adaptor Kits

For LF and TF Series Actuators



## ZG-LF2 Crank Arm Adaptor Kit

For LF Series Actuators

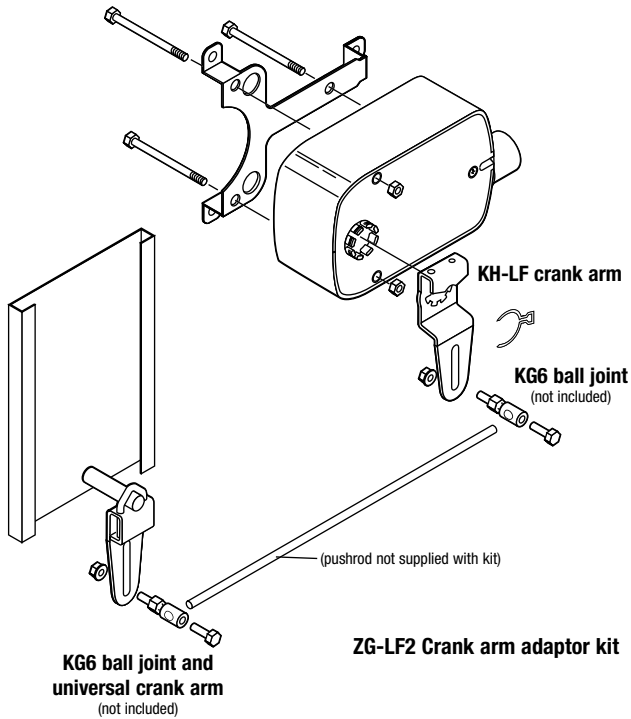

### Application

The ZG-LF2 Crank Arm Adaptor Kit is designed for applications where the actuator cannot be mounted directly to the damper shaft. It may be used for outside or inside the duct mounting.

### The ZG-LF2 Crank Arm Adaptor Kit includes:

- 1 Mounting Bracket
- 1 KH-LF Crank Arm with Retaining Ring
- 3 Bolts with Nuts

**NOTE:** May require crank arm and ball joints

The ZG-LF2 Crank Arm Adaptor Kit can be used to replace foot mounted, crank arm style actuators. The ZG-LF2 allows for easy retrofit of Honeywell™, Siebe™ (Barber Coleman™), and Johnson Controls™ actuators.

## ZG-TF2 Crank Arm Adaptor Kit

For TF Series Actuators

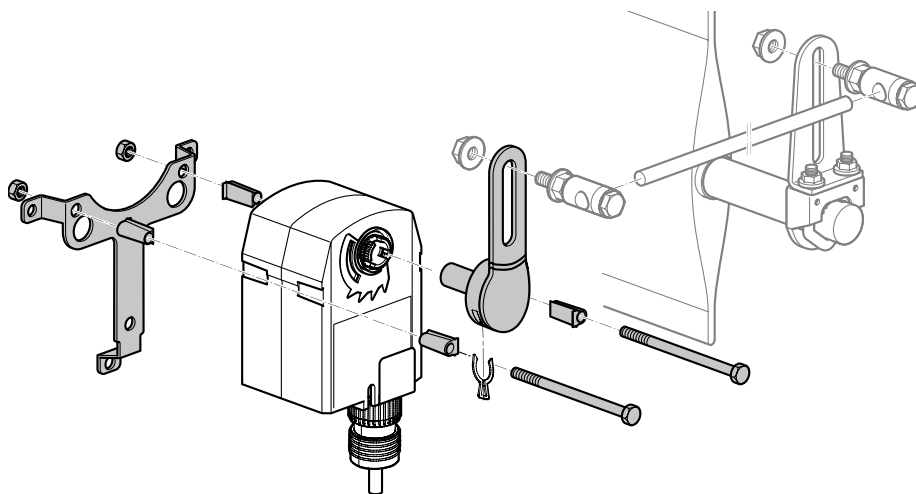

### Application

The ZG-TF2 Crank Arm Adaptor Kit is designed for applications where the actuator cannot be mounted directly to the damper shaft. It may be used for outside or inside the duct mounting.

### The ZG-TF2 Crank Arm Adaptor Kit includes:

- 1 Mounting Bracket
- 1 KH-TF-1 Crank Arm with Retaining Clip
- 3 Bolts with Nuts

**NOTE:** May require crank arm and ball joints

The ZG-TF2 Crank Arm Adaptor Kit can be used to replace foot mounted, crank arm style actuators. The ZG-TF2 allows for easy retrofit of Honeywell™, Siebe™ (Barber Coleman™), and Johnson Controls™ actuators.

M40024 - 05/10 - Subject to change. © Belimo Aircontrols (USA), Inc.

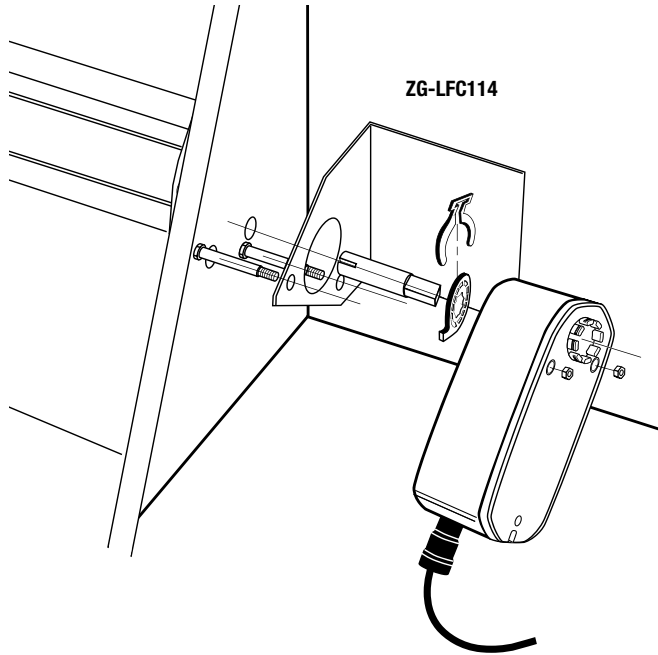

### Application

The ZG-LFC114 Crank Arm Adaptor Kit is designed for Trane voyager economizer actuator retrofit.

#### The ZG-LFC114 Crank Arm Adaptor Kit includes:

- 1 Mounting Bracket
- 1 Shaft Adaptor
- 2 Bolts with Nuts
- 4 Female Spade Connectors

Note: May require crank arm and ball joints

#### USE WHEN REPLACING THESE ACTUATORS

Honeywell	M84...	M7...
-----------	--------	-------

#### OTHER CRANK ARM ADAPTOR KITS AND UNIVERSAL MOUNTING BRACKETS

KIT	MOUNTING BRACKET*	ACTUATOR USED WITH
ZG-AFB	NA	AFB, AFX, NFB, NFX
ZG-AFB118	ZG-118	AFB, AFX, NFB, NFX
ZG-AF108	ZG-108 (Included)	AF
ZG-AF US	ZG-100, ZG-101	AF
ZG-LF112	ZG-112 (Included)	LF
ZG-LF2	NA	LF
ZG-LFC114	NA	LF
ZG-ECON1	ZG-112 (Included)	LF
ZG-ECON2	ZG-112 (Included)	LF
ZG-TF112	ZG-113 (Included)	TF
ZG-TF2	NA	TF
ZG-GMA	ZG-101, ZG-101, ZG-103, ZG-104	GM
ZG-NMA	ZG-101, ZG-101, ZG-103, ZG-104	NM, AM
NA	ZG-106	AF
NA	ZG-107	AF
NA	ZG-107	AF

\*Unless otherwise noted, mounting brackets are not included in crank arm adaptor kits.

# ZG-ECON1 and ECON2 Crank Arm Adaptor Kits

For LF and Series Actuators



## ZG-ECON1 Crank Arm Adaptor Kit

For LF Series Actuators

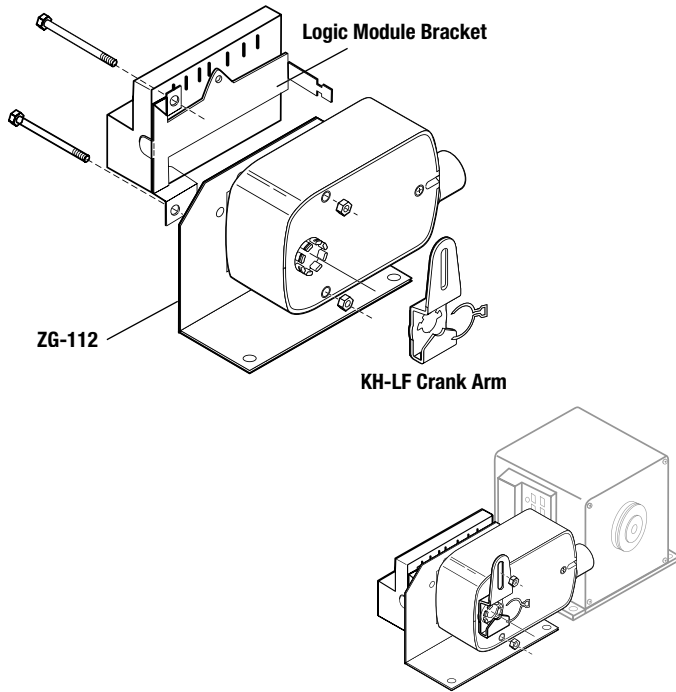

### Application

The ZG-ECON1 Crank Arm Adaptor Kit is designed for applications where the actuator cannot be mounted directly to the damper shaft. It may be used for outside or inside the duct mounting.

#### The ZG-ECON1 Crank Arm Adaptor Kit includes:

- 1 ZG-112 Mounting Bracket
- 1 Logic Module Mounting Bracket (20477-00001)
- 1 KH-LF Crank Arm with Retaining Ring
- 1 KG6 Ball Joint
- 4 Male Spades
- 2 Bolts with Nuts

**NOTE:** May require crank arm and ball joints

The ZG-112 is provided with hole patterns to mount the LF series actuators in either a horizontal or vertical position to meet space requirements.

The ZG-112 Mounting Bracket is designed to mount the TF and LF series actuator in the same mounting locations as common foot mounted, crank arm style actuators. Hole patterns in the base match common Honeywell™, Siebe™ (Barber Coleman™), and Johnson Controls™ actuators for easy retrofit.

#### USE WHEN REPLACING THESE ACTUATORS

Honeywell	M84...	M7...
-----------	--------	-------

## ZG-ECON2 Crank Arm Adaptor Kit

For LF Series Actuators

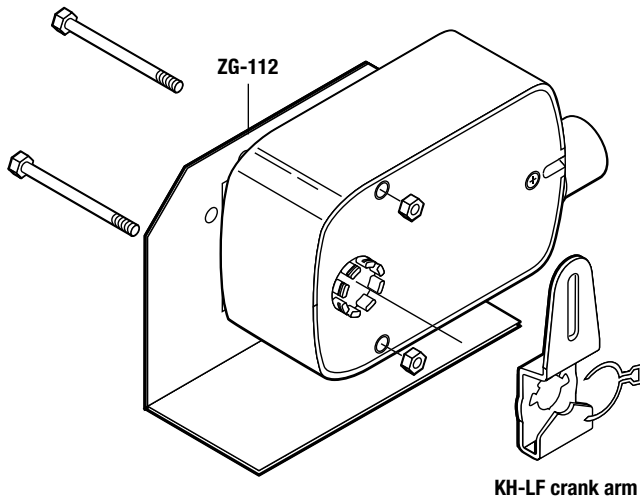

### Application

The ZG-ECON2 Crank Arm Adaptor Kit is designed for applications where the actuator cannot be mounted directly to the damper shaft. It may be used for outside or inside the duct mounting.

#### The ZG-ECON2 Crank Arm Adaptor Kit includes:

- 1 ZG-112 Mounting Bracket
- 1 KH-LF Crank Arm with Retaining Ring
- 1 KG6 Ball Joint
- 4 Female Spades
- 2 Bolts with Nuts

**NOTE:** May require crank arm and ball joints

The ZG-112 is provided with hole patterns to mount the LF series actuators in either a horizontal or vertical position to meet space requirements.

The ZG-112 Mounting Bracket is designed to mount the TF and LF series actuator in the same mounting locations as common foot mounted, crank arm style actuators. Hole patterns in the base match common Honeywell™, Siebe™ (Barber Coleman™), and Johnson Controls™ actuators for easy retrofit.

#### USE WHEN REPLACING THESE ACTUATORS

Honeywell	M84...	M7...
-----------	--------	-------

M40024 - 05/10 - Subject to change. © Belimo Aircontrols (USA), Inc.

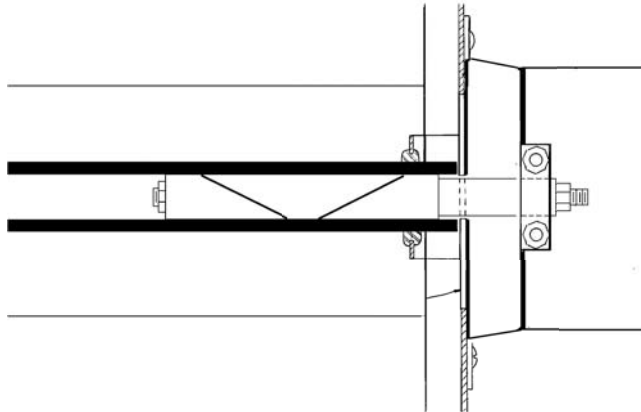

### Application

The ZG-JSA jack shaft adaptors are designed to be inserted into hollow jack shafts which have an outside diameter greater than 3/4 inch and provide a 3/4 inch shaft for mounting Belimo actuators.

Technical Data		ZG-JSA-1
Jack Shaft Size	Outside diameter	1.00"
	Inside diameter	3/4"
Weight		1.3 lbs.
Material		Cold rolled steel, nickel plated

Technical Data		ZG-JSA-2
Jack Shaft Size	Outside diameter	1-5/16"
	Inside diameter	1-3/32"
Weight		2.3 lbs.
Material		Cold rolled steel, nickel plated

Technical Data		ZG-JSA-3
Jack Shaft Size	Outside diameter	1.05"
	Inside diameter	27/32"
Weight		1.6 lbs.
Material		Cold rolled steel, nickel plated

**Dimensions (Inches [mm])**

	A (Diameter)	B (Diameter)	C	D
ZG-JSA-1	3/4"	3/4"	-	10-3/4"
ZG-JSA-2	1-1/16"	3/4"	6"	12-1/2"
ZG-JSA-3	13/16"	3/4"	6"	12-1/4"

M40024 - 05/10 - Subject to change. © Belimo Aircontrols (USA), Inc.

## ZS-100 Weather Shield



### Application

The ZS-100 weather shield provides moderate protection to actuators which are mounted outdoors. This product is not designed as a water tight enclosure. The weather shield will work with all damper actuators.

### Installation

The ZS-100 weather shield is supplied disassembled. Supplying it in this manner makes it applicable to a wider range of field applications.

It may be assembled with 2 sides, 2 ends and the cover to completely conceal the actuator. A hole punch can be used to provide a hole to mount a wire conduit. A foam gasket is also provided to achieve a better seal between the cover and sides or from the base to the mounting surface.

If desired, a side or end can be deleted from the assembly to provide easy access from the bottom of the enclosure.

### Accessories

**ZS-101** Base mounting plate

### Dimensions (Inches [mm])

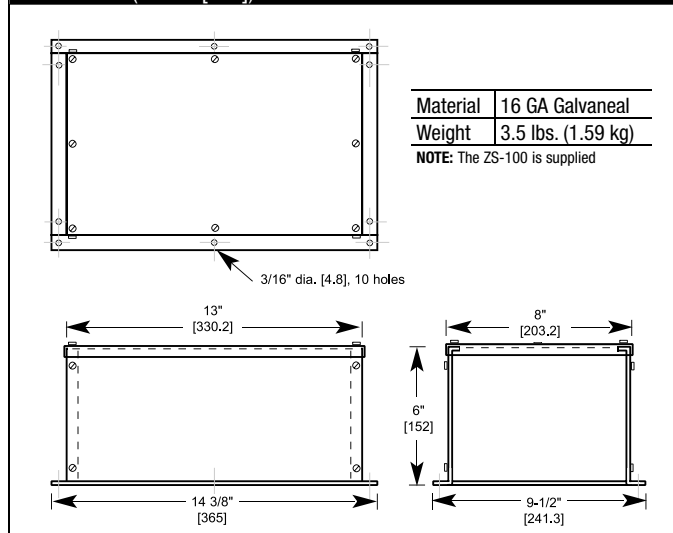

## ZS-150 Weather Shield



### Application

The ZS-150 weather shield provides moderate protection to actuators which are mounted outdoors. This product is not designed as a water tight enclosure. The one piece, smoke tinted, polycarbonate housing allows easy mounting over all damper actuators. The tinted, clear housing allows easy viewing of the actuator in operation.

### Installation

The ZS-150 weather shield is supplied as a one piece enclosure. Two 7/8 inch wiring holes are pre-drilled to allow easy connections of conduit to the housing. If connections must be made to a different spot on the enclosure or only one hole is required, two plastic plugs are provided to seal the holes. A foam gasket is also provided to achieve a better seal between the base of the enclosure to the mounting surface.

### Dimensions (Inches [mm])

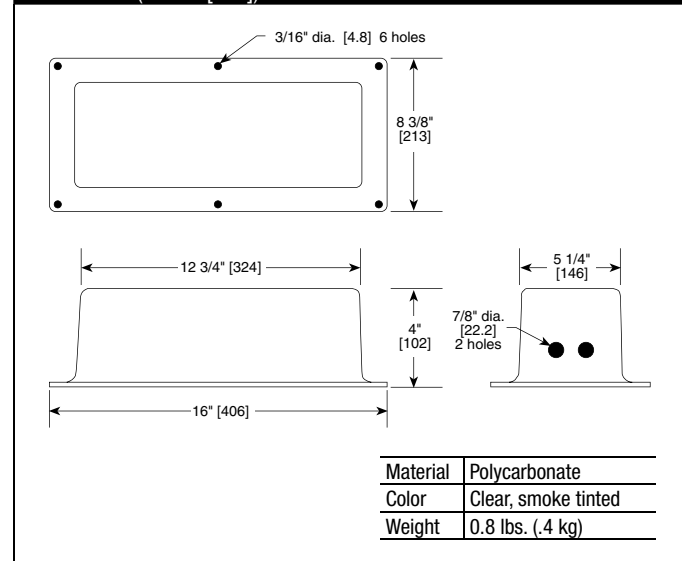

M40024 - 05/10 - Subject to change. © Belimo Aircontrols (USA), Inc.

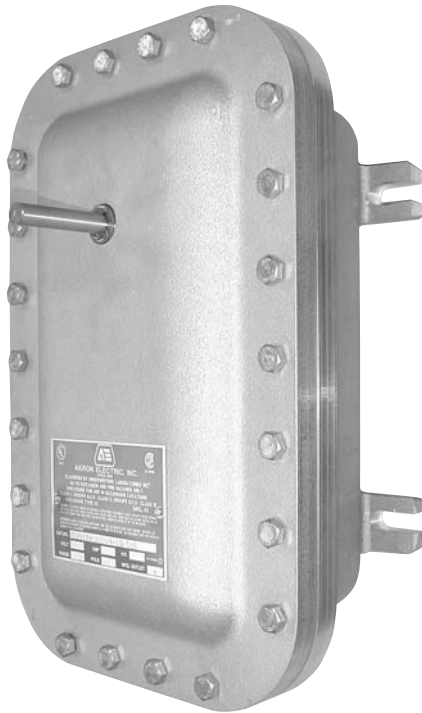

## Application

The ZS-260 explosion-proof housing may be used with the GM..., AM..., NFB..., NFX..., AFB..., AFX..., AF..., LF... series actuators. This housing is not designed for direct coupling. UL and CSA; Class I, Division 1&2, Groups B, C, D, (NEMA 7), Class II, Division 1&2, Groups E, F and G, (NEMA 9), Class III, Hazardous (classified) Locations, outdoor application NEMA 4X.

## Operation

The ZS-260 enclosure is designed so that the required actuator may be easily field mounted into the enclosure. The actuator is fastened on to the internal portion of the operating shaft and secured at the end with an anti-rotation strap. A crank-arm, such as the KH8, is mounted to the external portion of the operating shaft for connection to connection to the damper linkage. ZG-109 right angle, and ZG-110 standoff mounting brackets may be used (see back).

The ZS-260 is designed so that the operating shaft can be mounted on either the front or rear side of the housing.

## Accessories

<b>KH8</b>	Universal crank arm
<b>KG8</b>	Universal ball joint
<b>KG10</b>	Universal ball joint
<b>ZG-109</b>	Right angle mounting bracket
<b>ZG-110</b>	Stand-off mounting bracket

Technical Data		ZS-260
Material	Housing	cast, copper-free, aluminum,
	Cover Bolts	stainless steel
	Operating Shaft	stainless steel
Conduit holes		3/4"-14 NPT (2 supplied), <b>see NOTE 1</b>
Operating shaft diameter		1/2 inch [12.7]
Operating shaft location		front or rear side of housing (Field selected)
Approved applications		UL and CSA; Class I, Division 1&2, Groups B, C, D, (NEMA 7), Class II, Division 1&2, Groups E, F and G, (NEMA 9), Class III, Hazardous (classified) Locations, outdoor application NEMA 4X.
Weight		31.0 lb. (14.0 kg) without actuator

**NOTE 1:** Fittings that meet the requirements of the hazardous location must be used. All applications must comply with applicable local and/or national electric code.

**NOTE:** Since conditions of use of this product are outside the control of Belimo, the purchaser should determine suitability of the product for their intended use, and assumes all risk and liability in connection therewith.

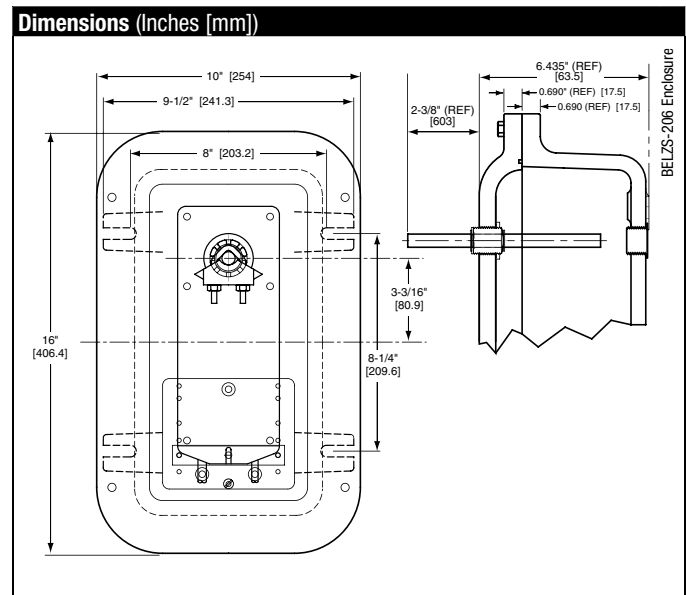



# ZS-260 Explosion-proof Housing

For GM..., AM..., AFB..., AFX..., NFB..., NFX..., LF... Actuators



## ZS-260 Shaft Thru Front

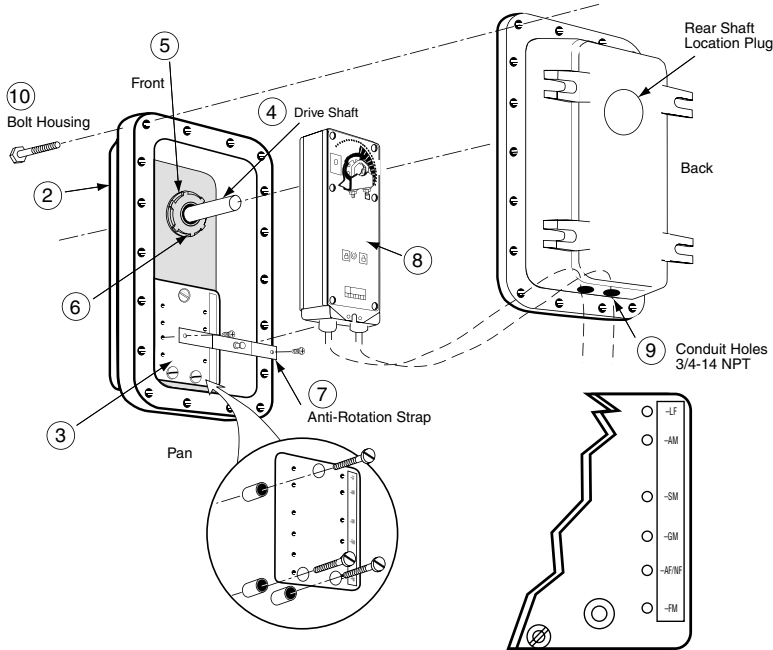

### ZS-260 Mounting Instructions

1. Determine proper operating shaft location.
2. Remove threaded plug from the hole in which the operating shaft will be mounted.
3. Install the anti-rotation strap, mounting plate, to the side of the housing where the operating shaft will be mounted.
4. From the inside surface of the housing, insert the operating shaft, short length first, into the mounting hole.
5. Hand tighten the shaft bushing into the housing until the star nut/seal is in contact with the face of the housing.
6. Using a screw driver blade, drive the star nut/seal clockwise until the bushing is locked into place.
7. Install the anti-rotation strap into the mounting plate at the designated holes for the actuator to be used.
8. Install actuator.
9. Wire actuator (per electrical code).
10. Bolt housing together.

## Typical ZG-109 Mounting

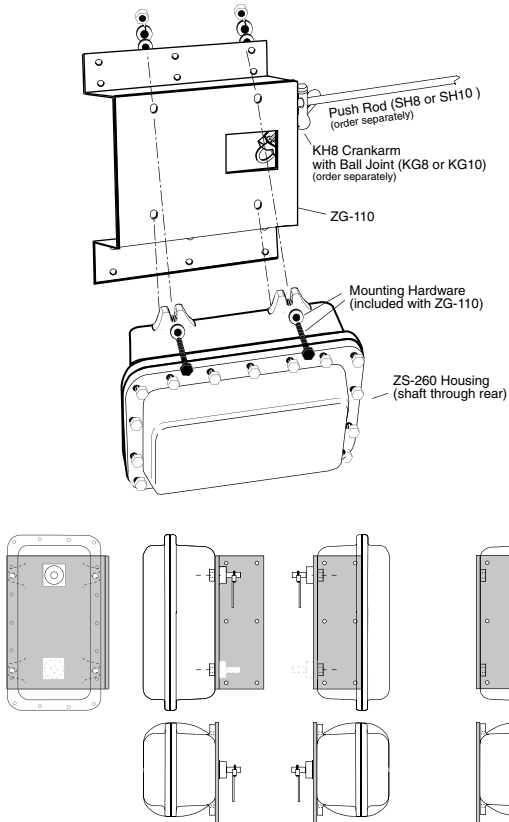

## Typical ZG-110 Mounting

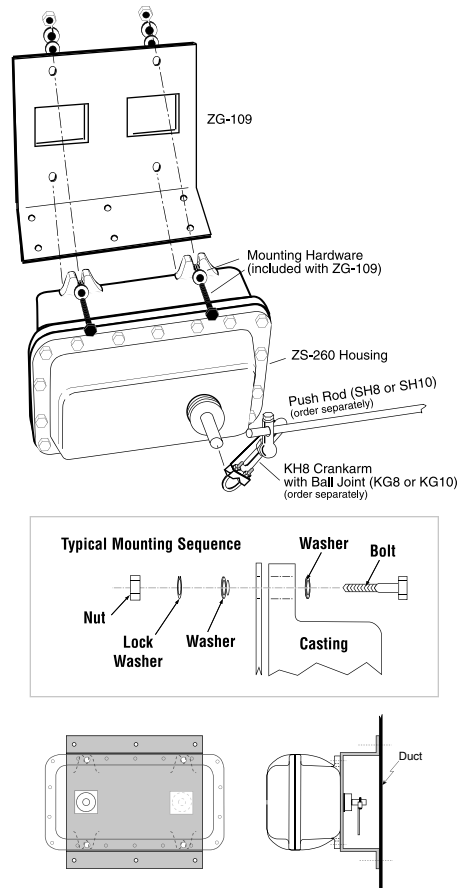

M40024 - 05/10 - Subject to change. © Belimo Aircontrols (USA), Inc.



ZS-300

## ZS-300 NEMA 4X Housing

For AMB, GMB, LF, NFB, NFX, AFB, AFX, AF Series Actuators

### Application

The ZS-300 (-1) NEMA 4X enclosures may be used with AMB, GMB, LF, NF, and AF Belimo actuators. They are intended for use primarily to provide protection against corrosion, windblown dust and rain, splashing water, hose-directed water; undamaged by the formation of ice on the enclosure. Type 304 stainless steel enclosures resist moisture, dust, salt, and corrosive chemicals, and are easy to keep clean for sanitary applications.

### Operation

The ZS-300 enclosures are designed so that the required actuator may be easily mounted in the enclosure. The operating shaft and coupling are inserted from the backside through the rotating shaft seal. The actuator is fastened on the end of the operating shaft and secured at the end with an anti-rotation strap. Adjustable mounting brackets, if supplied, are assembled to the fixed mounting holes at the top and bottom of the enclosure with stainless steel nuts, bolts and lock washers. The direct drive coupling is designed for a 1/2" round or hexagonal shaft and secured with two square head set screws. Mounting brackets are adjusted and secured in place.

### Ordering Information

ZS-300	304 stainless steel housing with mounting brackets
ZS-300-1	304 stainless steel housing without mounting brackets
ZS-300-5	316L stainless steel housing with mounting brackets

### Accessories

ZS-300-BK	Mounting bracket set
ZS-300-C1	1/2" shaft adaptor (standard with housing)
ZS-300-C2	3/4" shaft adaptor
ZS-300-C3	1" shaft adaptor

Technical Data	ZS-300 (-1) (-5)
Material	All stainless steel housing, door, (with microcellular urethane gasket), shaft, coupling, universal mounting plate, and hardware.
Conduit holes	Field drilled as required. UL listed electrical fittings for NEMA 4X conditions must be used.
Drive shaft/coupler	1/2" by 5 15/16" long stainless steel with integral coupling for direct mounting to 1/2" round or hexagonal drive shafts. Square head set screws are stainless steel.
Rotating shaft seal	6061 aluminium hub with black anodize plating, bronze oilite bearings, 10 PSI, Nitrile, bi-rotational, hydrodynamic, radial lip Wave seal.
Industry standards	The Belimo ZS-300 NEMA 4X enclosure and Belimo model AMB, GMB, LF, NFB(X), AF, and AFB(X) are UL listed. These enclosures conform to the NEMA standard for Type 4X (water-tight, dust-tight and corrosion resistant).
Weight	11 lbs. [5 kg] without actuator or mounting brackets.

### Dimensions (Inches [mm])

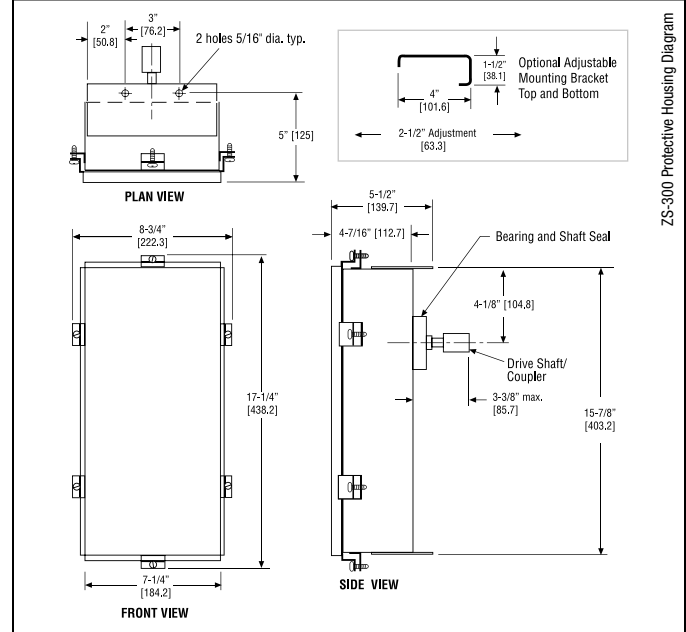

ZS-300 Protective Housing Diagram

M40024 - 05/10 - Subject to change. © Belimo Aircontrols (USA), Inc.

# ZS-300 (-1, -5)

NEMA 4X, stainless steel, corrosion resistant enclosures for AM, GM, NFB, NFX, AFB, AFX and AF actuators



## ZS-300 Mounting Instructions

1. The damper operating shaft should extend approximately 1-1/2 inches from the damper assembly or duct side. Mount the drive shaft/coupler (1) to the damper operating shaft (2). Fasten the coupler to the damper operating shaft by tightening the two 3/8 inch square head set screws (3).
2. Determine the housing mounting orientation for the application.
3. Locate the housing hole position(s) for the control wiring of the actuator.
4. Make the necessary holes in the housing for the electrical fittings. All fittings must be rated for use in NEMA 4X applications.
5. Install (if ordered with) the 2 mounting brackets (4) to the housing using the four 1/4-20 screws, washers, and nuts (5). Do not tighten.
6. Carefully slide the housing over the drive shaft.
7. Place the housing in the desired mounting position. Transfer the mounting hole locations from the mounting bracket to the mounting surface.
8. Drill the 4 holes and fasten the brackets to the surface.
9. Install the anti-rotation strap to the housing in the correct location for the actuator which is being used.
10. Mount the actuator to the drive shaft using the instructions for the actuator being used. Finger tighten the nuts of the universal clamp. Make sure the back of the actuator is parallel to the back of the housing.
11. The operating shaft must pass through the mounting clamp at least 3/8 of an inch. It must not extend beyond the front of the housing. Slide the actuator/housing assembly in the mounting brackets to obtain the proper position.
12. Tighten the mounting brackets to the housing. Verify that the back of the actuator is still parallel to the back of the housing. Tighten the nuts on the universal clamp.
13. Make all of the required electrical connections.
14. Test the actuator/damper operation.
15. Fasten the housing cover (6) using the 6 swivel clamps.

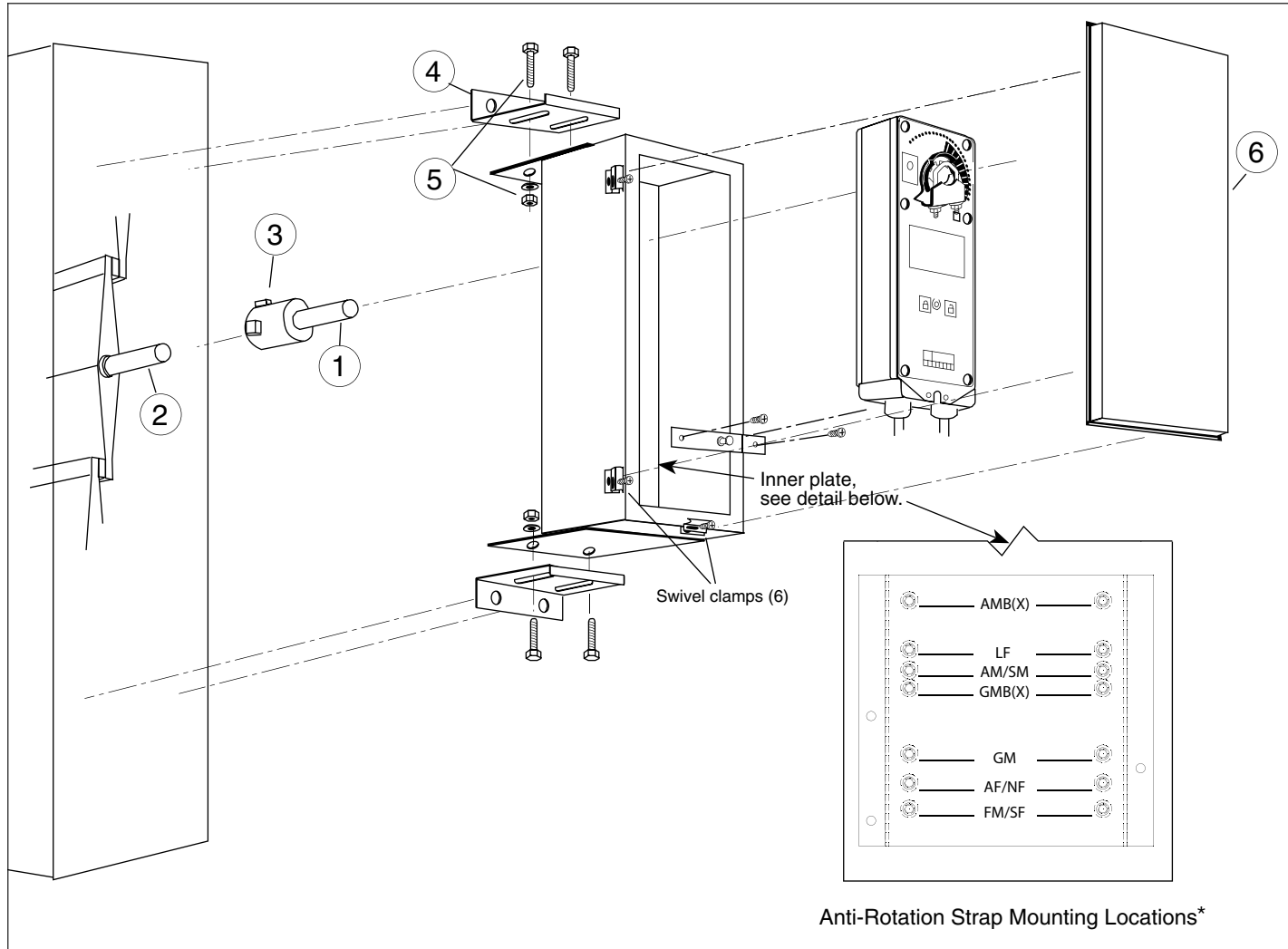

\*AFB, AFX, NFB and NFX can be installed using GM mounting location without the need of the Z-AF retrofit bracket.

M40024 - 05/10 - Subject to change. © Belimo Aircontrols (USA), Inc.