

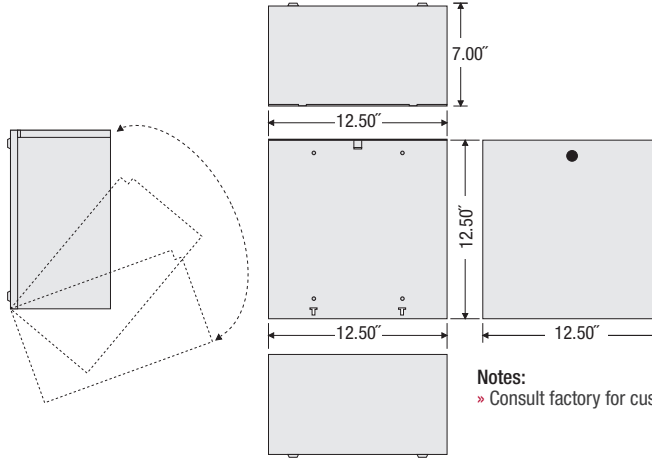

Enclosure

MH3300 SERIES

Metal Housing, NEMA 1, 12.50" H x 12.50" W x 7.00" D



Notes:
 » Consult factory for custom colors

■ SPECIFICATIONS

Construction: 18 Gauge Steel
 Weight: 9.10 lbs.
 Approvals: UL Listed, C-UL, CE Approved, RoHS

MH3300 Series Assemblies

MODEL #	ENCLOSURE	COVER TYPE	SUB-PANEL
MH3300	MH3300	Vertical Lift Screw Down	
MH3300K	MH3300K	Vertical Lift Key Latch	
MH3303	MH3300	Vertical Lift Screw Down	SP3303
MH3304	MH3300	Vertical Lift Screw Down	SP3304
MH3303K	MH3300K	Vertical Lift Key Latch	SP3303
MH3304K	MH3300K	Vertical Lift Key Latch	SP3304

Notes