

APPLICATION

Linkage for connection MM and MMR-400/500 Series Modular Motors to dampers.

Each AM-230 kit contains:

- One (1) AM-230 Motor crank arm assembly for connecting to square shafts of MM & MMR-400/500 Series Modular Motor
- One (1) Shaft retainer clip
- One (1) General Instruction Sheet

Each AM-234 kit contains:

- One (1) AM-230 Motor crank arm kit for connecting to square shafts of MM & MMR-400/500 Series Modular Motor
- One (1) AM-113 damper crank arm for 1/2" diameter damper shaft
- Two (2) AM-132 ball joint linkage connectors
- One (1) AM-301 Motor mounting kit
- Four (4) #10 x 3/4" round head sheet metal screws
- Four (4) 1/4-20 x 3/4" hex head bolts (with washers and nuts)
- One (1) General Instruction Sheet

Each AM-235 kit contains:

- One (1) AM-230 Motor crank arm kit for connecting to square shafts of MM & MMR-400/500 Series Modular Motor
- Three (3) AM-113 damper crank arms for 1/2" diameter damper shaft
- Four (4) AM-132 ball joint linkage connectors
- One (1) AM-301 Motor mounting kit
- Four (4) #10 x 3/4" round head sheet metal screws
- Four (4) 1/4-20 x 3/4" hex head bolts (with washers and nuts)
- One (1) General Instruction Sheet

Other Schneider Electric Components Required:

MM or MMR Modular Motor, MMC Control Module, and other required accessories.

Other Schneider Electric Components That May Be Required:

- AM-125-XXX Damper rod
- AM-111 For 5/16" diameter damper shaft
- AM-112 For 3/8" diameter damper shaft
- AM-113 For 1/2" diameter damper shaft (included in AM-234 and AM-235 kits)
- AM-115 For 7/16" diameter damper shaft

PRE-INSTALLATION

Inspection

Visually inspect the package for damage. If damaged, notify the appropriate carrier immediately. If undamaged, open the package and visually inspect the device for obvious defects. Return damaged or defective products.

Required Installation Items

- Tools (not provided):
Appropriate screwdriver and wrenches.

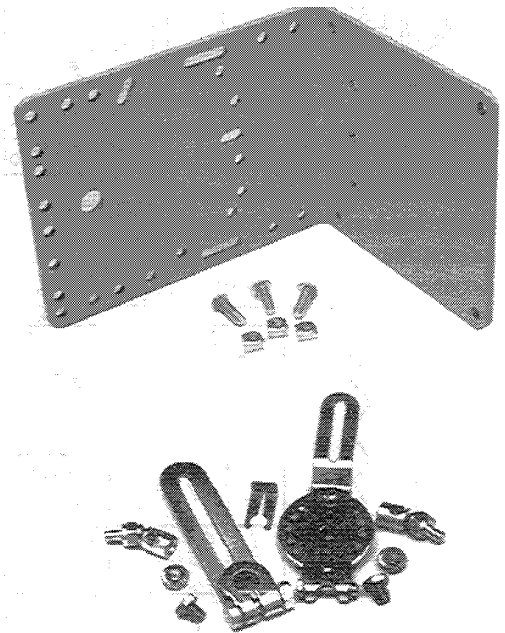

AM-234 Shown

INSTALLATION

Caution:

1. Installer must be a qualified, experienced technician.
2. MM-400/500 Series and MMR-400/500 Series General Instruction sheets contain specific information on modular motor installation.
3. Avoid locations where excessive moisture, corrosive fumes or vibration are present. AM-230 Series linkages are intended for mounting only to the MM-400/500 Series and MMR-400/500 Series Modular Motors.
4. Damper rod (AM-125-XXX) should be:
 - a. Long enough for easy adjustment.
 - b. Short enough to be rigid, providing good damper response.

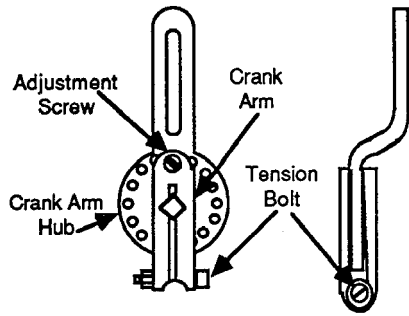

Figure-1 Crank Arm/Hub AM-230.

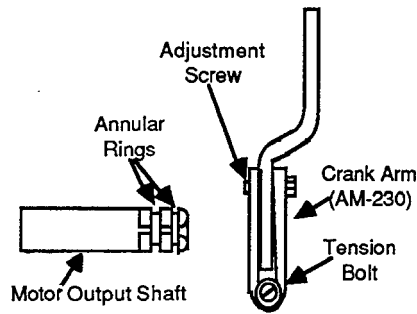

Figure-2 Crank Arm Mounting to Motor Output Shaft.

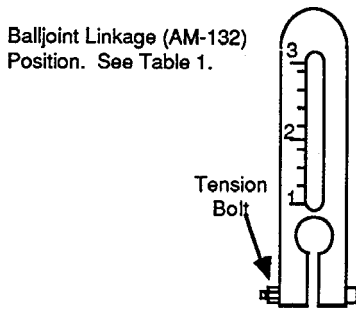

Figure-3 Balljoint Linkage Position on Damper Crank Arm AM-11X.

LINKAGE MOUNTING

Table-1 Position of Ball Joint on Damper Crank Arm.
(Ball Joint at minimum position on motor crank arm.)

Motor Rotation	Damper Rotation				
	40°	50°	60°	75°	90°**
75°	2-11/16 (68)	2-3/16 (56)	1-13/16 (46)	1-1/2 (38)	1-5/16 (33)
90°	3-1/8 (79)	2-1/2 (64)	2-1/8 (54)	1-3/4 (44)	1-1/2 (38)
110°	3-9/16 (90)*	2-7/8 (73)	2-7/16 (62)	2 (51)	1-3/4 (44)
160°	4-5/16* (110)	3-1/2* (89)	2-15/16 (75)	2-7/16 (62)	2-1/16 (52)

Dimensions in inches (mm).

* not obtainable with standard AM-11X damper crank arm.

** Recommended damper rotation for two position control.

See Figures 1 through 4 and Table 1.

1. Align the modular motor output shaft to the shaft hole in the motor crank arm/hub (AM-230) and insert the crank arm/hub (AM-230) on the motor output shaft.
2. Finger tighten the motor crank arm/hub screws at this phase of the installation.

Note: Do not install retainer clip until adjustments are complete.

3. Insert the damper crank arm on the damper shaft (AM-113 for 1/2" dia. shaft). Position the damper blades in the position required with the motor in CCW (counterclockwise) position (as viewed from the "Load" or "Load, Normally Closed-CCW Spring Return" end).

Note: The crank arm must be firmly installed on the motor output shaft and rest against the output shaft shoulder.

4. Finger tighten the damper crank arm screws only at this point of the installation.
5. Install a ball joint linkage (AM-132) as close as possible to motor output shaft.
6. Install a ball joint linkage (AM-132) at the positions shown on the damper crank arm (see Figure 3) - adjust after linkage is assembled and the motor is run through its stroke.

Two Position Damper Ball Joint Position on Damper Crank Arm (See Figure 3 and Table 1)

Set the ball joint on the damper crank arm as indicated in Table 1. the damper will be completely open or completely closed if required by a two position controller.

Proportional Damper Ball Joint Position on Damper Crank Arm (See Figure 3 and Table 1)

Set the ball joint on the damper crank arm (see Table 1). A damper set to open at 60° will allow approximately 96% of the maximum air flow through the damper. Further damper opening will pass little, if any, additional air. Motor shaft rotation of 160° and a maximum damper shaft rotation of 60° will provide the best possible air flow control by the damper.

7. Assemble the pushrod to the ball joints. Finger tighten the ball joint setscrews.

ADJUSTMENTS

See Figure 5.

1. Position the damper midstroke.
2. Slide the motor crank arm off the output shaft.
3. With the motor output shaft in line with the motor crank arm rotate the motor crank arm around the motor output shaft axis and the damper crank arm around the damper shaft until both crank arms are perpendicular to the imaginary line between the motor and damper shafts.
4. Tighten the set screws on the damper crank arm and ball joint.
5. With the motor crank arm still off the output shaft:
 - a. Rotate the motor crank arm CW (clockwise) through the remainder of the motor stroke.

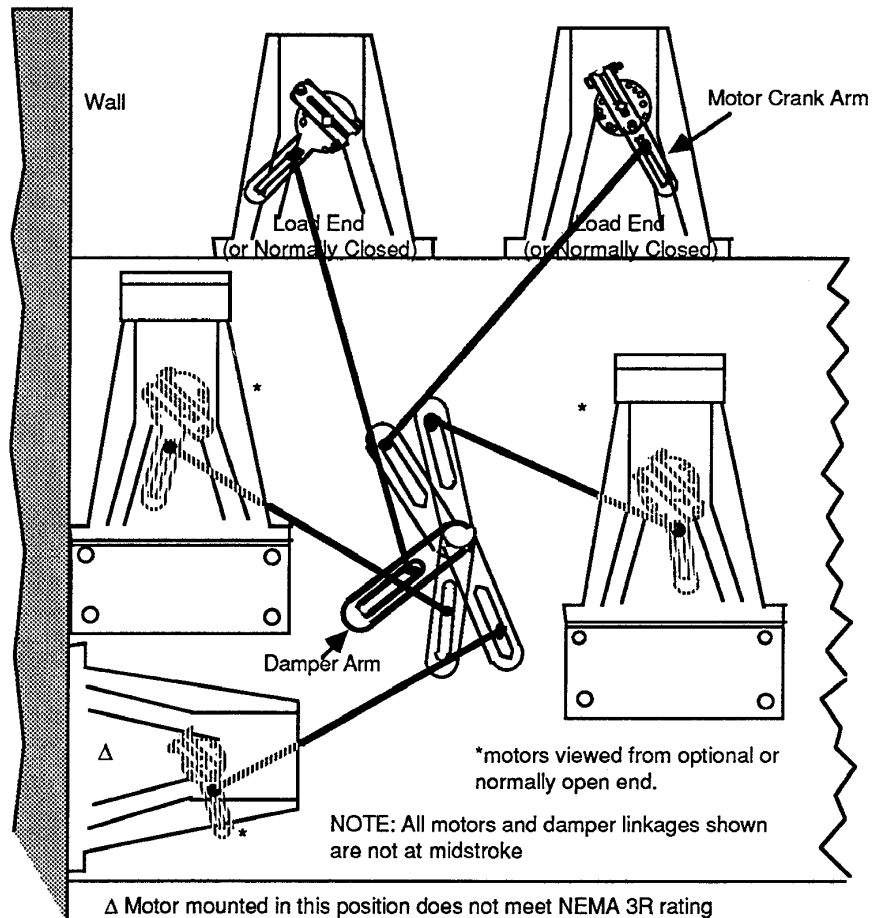

Figure-4 Typical Motor Mounting and Damper Linkage.

Note: Clockwise reference to the motor output shaft rotation is as seen from the “Load” or “Load, Normally Closed - CCW Spring Return” end of the motor.

- b. Rotate the motor crank arm CCW to the position that corresponds to the start of the stroke (the motor de-energized position).

Complete steps a and b several times to confirm that the damper and linkage will operate freely.

6. With the crank arm position corresponding to the CCW end (the motor de-energized position), slip the motor crank arm on the motor output shaft.

Note: It may be necessary to re-position the crank arm/hub by removing the adjustment screw and inserting it in another hole on the hub.

7. Insert retainer clip between crank arm and crank hub (See Figure 6).

Note: The adjustment screw must be loose to provide clearance for retainer clip insertion.

8. Tighten the motor crank arm adjustment screw.
9. Tighten the motor crank arm tension bolt.

CHECKOUT

1. Power the motor and run it through its complete stroke:
 - a. If linkage binding occurs, release one of the connectors to prevent damage.
 - b. Make certain that any extra length of pushrod does not foul and stall the motor.
 - c. Note that the motor rotates and linkage/damper moves smoothly through-out the stroke

Caution: If crank arm does not provide proper travel, reset connecting link in linkage connector. NEVER ATTEMPT TO TURN THE MOTOR SHAFT WITH A WRENCH OR A CRANK. This will cause internal damage.

2. Tighten all nuts and screws after making all adjustments.
3. Linkage assembly and adjustment is now complete.

MAINTENANCE

Regular maintenance of the total system is recommended to assure sustained optimum performance.

FIELD REPAIR

None. Replace damaged components with functional linkage.

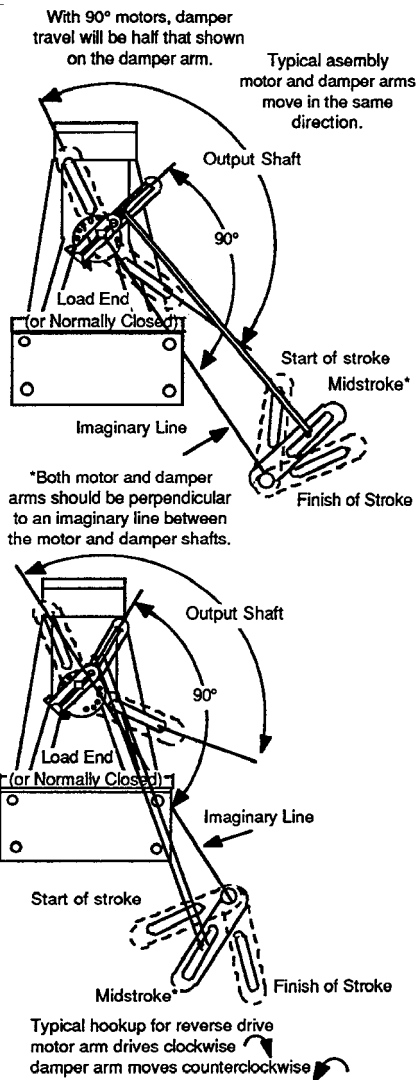

Figure-5 Typical Damper Linkage Position - Motor Crank Arm Position May Change Due to Damper Location.

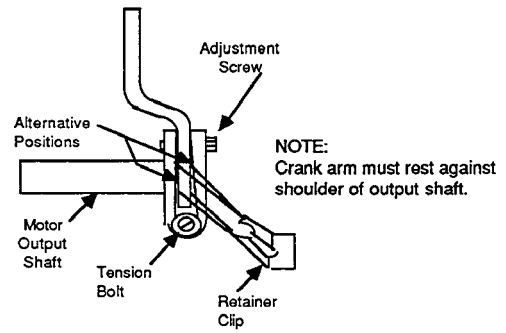

Figure-6 Retaining Clip Location.

On October 1st, 2009, TAC became the Buildings business of its parent company Schneider Electric. This document reflects the visual identity of Schneider Electric, however there remains references to TAC as a corporate brand in the body copy. As each document is updated, the body copy will be changed to reflect appropriate corporate brand changes.

Copyright 2010, Schneider Electric
 All brand names, trademarks and registered trademarks are the property of their respective owners. Information contained within this document is subject to change without notice.

Schneider Electric
 1354 Clifford Avenue
 P.O. Box 2940
 Loves Park, IL 61132-2940

www.schneider-electric.com/buildings

Schneider
 Electric