

AMCX24-MFT

Proportional, Non-Spring Return, 24 V, Multi-Function Technology®



MFT



Technical Data	AMCX24-MFT
Power supply	24 VAC ± 20% 50/60 Hz 24 VDC ± 10%
Power consumption	4 W (1.25 W)
Transformer sizing	6 VA (Class 2 power source)
Electrical connection	18 GA plenum rated cable 1/2" conduit connector protected NEMA 2 (IP54) 3 ft [1m] 10 ft [3m] 16 ft [5m]
Overload protection	electronic throughout 0 to 95° rotation
Operating range Y	2 to 10 VDC, 4 to 20 mA (default) variable (VDC, PWM, floating point, on/off)
Input impedance	100 kΩ (0.1 mA), 500 Ω 1500 W (PWM, floating point, on/off)
Feedback output U	2 to 10 VDC, 0.5 mA max VDC variable
Angle of rotation	max. 95°, adjustable with mechanical stop electronically variable
Torque	180 in-lb [20 Nm]
Direction of rotation	reversible with switch
Position indication	reflective visual indicator (snap-on)
Manual override	external push button
Running time	35 seconds (default) variable (35 to 120 seconds)
Humidity	5 to 95% RH non condensing (EN 60730-1)
Ambient temperature	-22°F to 122°F [-30°C to 50°C]
Storage temperature	-40°F to 176°F [-40°C to 80°C]
Housing	NEMA 2, IP54, UL enclosure type 2
Housing material	UL94-5VA
Agency listings†	cULus acc. to UL 60730-1A/-2-14, CAN/CSA E60730-1:02, CE acc. to 2004/108/EEC and 2006/95/EC
Noise level	<45dB(A)
Servicing	maintenance free
Quality standard	ISO 9001
Weight	2.6 lbs [1.2 kg]

Torque min. 180 in-lb for control of damper surfaces up to 45 sq ft.

Application

For proportional modulation of dampers in HVAC systems. Actuator sizing should be done in accordance with the damper manufacturer's specifications.

The actuator is mounted directly to a damper shaft up to 1.05" in diameter by means of its universal clamp, 1/2" self-centered default. A crank arm and several mounting brackets are available for applications where the actuator cannot be direct coupled to the damper shaft.

The default parameters for 2 to 10 VDC applications of the ...MFT actuator are assigned during manufacturing. If necessary, custom versions of the actuators can be ordered. The parameters can be changed by two means: pre-set and custom configurations from Belimo or on-site configurations using the Belimo PC-Tool software.

Operation

The actuator is not provided with and does not require any limit switches, but is electronically protected against overload. The anti-rotation strap supplied with the actuator will prevent lateral movement.

The AMX series provides 95° of rotation and a visual indicator indicates position of the actuator. When reaching the damper or actuator end position, the actuator automatically stops. The gears can be manually disengaged with a button on the actuator cover.

The AMCX24-MFT actuators use a brushless DC motor, which is controlled by an Application Specific Integrated Circuit (ASIC). The ASIC monitors and controls the actuator's rotation and provides a digital rotation sensing (DRS) function to prevent damage to the actuator in a stall condition. Power consumption is reduced in holding mode.

Add-on auxiliary switches or feedback potentiometers are easily fastened directly onto the actuator body for signaling and switching functions

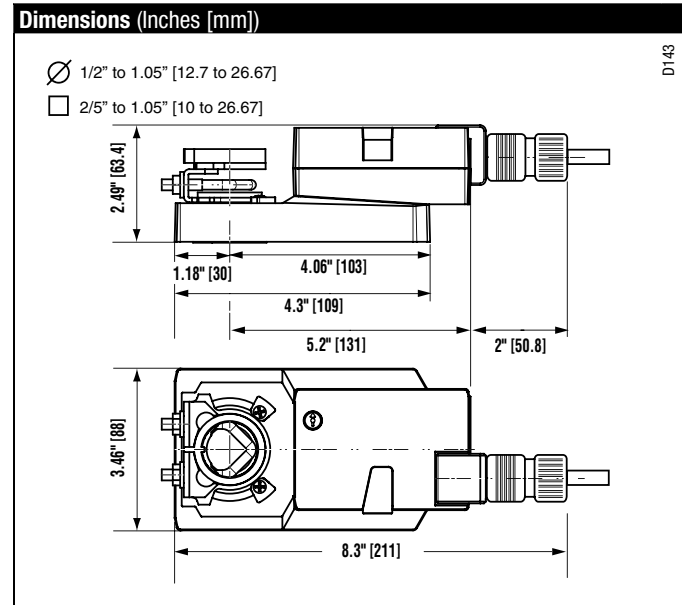

M40024 - 05/10 - Subject to change. © Belimo Aircontrols (USA), Inc.

Accessories

K-SA	Reversible Clamp
ZG-100	Universal Mounting Bracket
ZG-101	Universal Mounting Bracket
ZG-103	Universal Mounting Bracket
ZG-104	Universal Mounting Bracket
Z-SMA	AM/SM to AM Retrofit Mounting Bracket
ZG-AMA	Crank arm Adaptor Kit
AV8-25	Universal Shaft Extension
ZG-JSA (-1, 2, 3)	Jackshaft Adaptors for Hollow Jackshafts
ZS-100	Weather Shield - Steel
ZS-150	Weather Shield - Polycarbonate
ZS-260	Explosion Proof Housing
ZS-300 (-1) (-5)	NEMA 4X Housing
Tool-06	8 mm & 10 mm Wrench
S1A, S2A	Auxiliary Switch(es)
P370	Shaft Mount Auxiliary Switch
P...A	Feedback Potentiometers
SGA24	Min positioners in NEMA 4 housing
SGF24	Min positioners for flush panel mounting
ADS-100	Analog to Digital Switch
ZG-R01	Resistor for 4 to 20 mA Conversion
NSV24	US Battery Back-Up Module
ZG-X40	Transformer

Note: When using AMCX24-MFT... actuators, only use accessories listed on this page.

Typical Specification

Proportional control damper actuators shall be electronic direct coupled type, which require no crank arm and linkage and be capable of direct mounting to a shaft up to 1.05" diameter. Actuators must provide proportional damper control in response to a 2 to 10 VDC or, with the addition of a 500 Ω resistor, a 4 to 20 mA control input from an electronic controller or positioner. Actuators shall have brushless DC motor technology and be protected from overload at all angles of rotation. Actuators shall have reversing switch and manual override on the cover. Run time shall be constant and independent of torque. Actuators shall be cULus listed, have a 5-year warranty, and be manufactured under ISO 9001 International Quality Control Standards. Actuators shall be as manufactured by Belimo.

Wiring Diagrams

✂️ INSTALLATION NOTES

- 1 Provide overload protection and disconnect as required.
- 2 **CAUTION Equipment Damage!** Actuators may be connected in parallel if not mechanically mounted to the same shaft. Power consumption and input impedance must be observed.
- 3 Actuators may also be powered by 24 VDC.
- 4 Position feedback cannot be used with Triac sink controller. The actuator internal common reference is not compatible.
- 5 Control signal may be pulsed from either the Hot (source) or the Common (sink) 24 VAC line.
- 8 Contact closures A & B also can be triacs.
- 9 For triac sink the common connection from the actuator must be connected to the hot connection of the controller.

📄 APPLICATION NOTES

- ◆ The ZG-R01 500 Ω resistor may be used.

⚠️ WARNING Live Electrical Components!

During installation, testing, servicing and troubleshooting of this product, it may be necessary to work with live electrical components. Have a qualified licensed electrician or other individual who has been properly trained in handling live electrical components perform these tasks. Failure to follow all electrical safety precautions when exposed to live electrical components could result in death or serious injury.

