

SE7600E Series Application Guide

Schneider Electric SE7600E Series RTU Controller with IAQ Control Application Guide



CONTENTS

Solution Overview	2
Product Overview	3
Features & Benefits	3
System Overview & Architecture	4
Models Available	4
Terminal Identification & Function	5
Typical Application	5
Main Output Wiring	5
Proportional Heat Control	6
Indoor Air Quality Control Standards	6
AI1 CO2 Sensor Input Operation	6
Using any 0-10VDC value for monitoring	6
Using a 0-10VDC CO2 sensor for control purposes	7
Indoor Air Quality & Sequence of Operations	8
Economizer Control Mode Only	8
Economizer Mode and Fresh Air Measurement Station	9
Economizer Mode and CO2 Level Control	10
Economizer Mode, CO2 Level Control and Fresh Air Measurement Station	11

SE7600E SOLUTION OVERVIEW

It is not uncommon for most of us to spend up to 90% of our time indoors. A large portion of that time is often dedicated to a working environment in a commercial building. Studies conducted by the Environmental Protection Agency (EPA) show that indoor air can contain levels of pollutants that are actually higher than levels typically found outdoors.

In light of this, indoor air quality has become a major concern to businesses, building managers, tenants, and employees because of its direct impact on the comfort, well-being, and productivity of the building's occupants. Not all buildings have severe indoor air-quality issues, yet even well-run buildings can experience episodes of poor indoor air quality.

The Schneider Electric SE7600E Indoor Air Quality Controller (IAQ), along with your preferred CO2 sensor, is a cost-effective solution that is capable of controlling economizer-free cooling and IAQ demand-based ventilation strategy while providing a fresh air measurement input right out of the box. The Schneider Electric IAQ Controller replaces the need for custom programmed DDC controllers and sensors in order to achieve the same results as in the past. When connected to a building automation system, the Schneider Electric IAQ Controller can monitor and verify the CO2 and fresh air levels, ensuring that air quality and energy efficiency is optimized.

While primarily designed for use in small to midsized commercial building applications such as office buildings or schools, the Schneider Electric IAQ Controller can be installed in any other building type currently using a standard packaged rooftop or heat pump unit with a requirement for fresh air control. The Schneider Electric IAQ Controller provides a simple cost-effective solution. It offers advanced pre-programmed sequences of operations that can be installed without special software, tools or the presence of a network. This greatly reduces the installation cost and commissioning complexity while providing control functions immediately when powered on.

Further energy saving benefits can be achieved with the use of a local onboard passive infrared motion sensor (PIR) that can automatically detect local activity allowing the IAQ to be controlled only when occupants are present thus saving on unnecessary energy costs. This functionality along with configurable night setback features makes it an economical yet highly effective control solution, which brings IAQ control and energy savings features in one simple yet powerful package that is Network Ready, BACnet®, or ZigBee® Wireless compatible.

SE7600E SERIES PRODUCT OVERVIEW

The SE7600E series PI controller is specifically designed for RTU and Indoor Air Quality (IAQ) control. It is also designed for single stage, multi-stage, and or 0-10VDC analog heat control of heating or cooling equipment such as rooftop and self-contained units used in commercial applications and IAQ control via economizer control.

The product features an intuitive, menu-driven, back-lit LCD display, which walks users through the configuring steps making the process extremely simple. Accurate temperature control is achieved due to the product's PI time proportional control algorithm, which virtually eliminates temperature offset, associated with traditional, differential-based controllers. IAQ control is achieved due to CO2 and airflow measurement and fresh air damper control using two analog inputs.

The controllers are also compatible with the new Schneider Electric PIR cover accessories. Controllers equipped with a PIR cover provide advanced active occupancy logic, which will automatically switch occupancy levels from Occupied to Unoccupied as required by local activity being present or not. This advanced occupancy functionality provides advantageous energy savings during occupied hours without sacrificing occupant comfort. All controllers can be ordered with or without a factory installed PIR cover (see ordering notes below).



SE7600E Series

FEATURES AND BENEFITS

Features	Benefits
Controls IAQ with a remote return duct or wall CO2 sensor.	Being able to control IAQ means healthier & more productive occupants.
Controls and measure fresh air with a fresh air measurement station.	Meets new IAQ requirements and regulations for LEED type buildings.
Embedded free cooling economizer loop.	True energy savings with adjustable economizer control loop. Minimum fresh air can be measured and controlled with the fresh air measurement station.
One small compact thermostat-like controller.	Simple to install cost effective package. Easy thermostat-like operation for the end user.
Network ready functionality built in.	Allows for future network functionality along with remote monitoring of all critical system data points for sustainability.
PIR sensor cover available as an accessory.	Further energy savings is possible with the use of local PIR cover to automatically detect local occupancy. IAQ is maintained and controlled only when occupants are present to save energy costs.

SYSTEM OVERVIEW AND ARCHITECTURE

The SE7600E series PI controller is specifically designed for RTU and Indoor Air Quality (IAQ) control. It is also designed for single stage, multi-stage, and or 0-10VDC analog heat control of heating or cooling equipment such as rooftop and self-contained units used in commercial applications and IAQ control via economizer output.

The product features an intuitive, menu-driven, back-lit LCD display, which walks users through the configuring steps making the process extremely simple. Accurate temperature control is achieved due to the product's PI time proportional control algorithm, which virtually eliminates temperature offset, associated with traditional, differential-based controllers. IAQ control is achieved due to CO2 and airflow measurement and fresh air damper control using two analog inputs.

The controllers are also compatible with the new Schneider Electric PIR cover accessories. Controllers equipped with a PIR cover provide advanced active occupancy logic, which will automatically switch occupancy levels from Occupied to Unoccupied as required by local activity being present or not. This advanced occupancy functionality provides advantageous energy savings during occupied hours without sacrificing occupant comfort. All controllers can be ordered with or without a factory installed PIR cover (see ordering notes below).

They also feature a discharge air sensor input. Particularly, the SE7600E series features a 0-10VDC fresh air damper output that can be used to for free cooling (economizer function) and/or for CO2 level control.

The following hardware is required for operation of the RTU controller, but not included:

- 24 VAC power supply. Typically taken directly from the RTU power supply (C & RC).
- A spring return 0-10VDC damper actuator.
- An outdoor air sensor.
- A supply air duct sensor.
- A return air duct sensor (optional) or Room.
- Proper wiring of all components as per the installation manual.
- Proper network wires pulled through all devices communication connections.
- A 0-10 Vdc Fresh air measurement station.
- A 0-10 Vdc 0-2000 PPM room or return duct CO2 sensor.

Models Available

Application	Model
Model (with schedule)	SE7656E5x45(X)
Model (without schedule)	SE7606E5x45(X)

Ordering Information Notes:

- (X) model number represents available communication options:

() : Not communicating, network Ready

(B) : BACnet™ MS/TP

(W) : ZigBee Wireless

(P) : ZigBeePro Wireless

- Controllers can be ordered with a factory installed PIR cover. Please use (5545X) extension instead of the (5045X) only extension. Ex. SE7606B5545B.

- Controllers ordered without a PIR cover can be retrofitted with a separate PIR accessory cover afterwards when required.

TERMINAL IDENTIFICATION & FUNCTION

Terminal Use	Terminal Identification	Description
1 – Cool 2	Y2	Output for cooling / compressor stage number 2.
2 – Cool 1	Y1	Output for cooling / compressor stage number 1.
3 – Fan	G	Output for the fan.
4 – 24 V ~ Hot	RC	Power supply of thermostat, hot side (Delivered from the RTU).
5 – 0 V ~ Com	C	Power supply of thermostat, common side. Also used as reference for the analog signal(s).
6 – Heat Switch Leg	RH	24 VAC switched leg for the heating stages. <ul style="list-style-type: none"> •If heating stages are part of RTU, install a jumper across RC & RH. •If heating stages are part of separate equipment with a different power supply, feed external switched power leg through RH without installing a jumper across RC & RH.
7 – Heat 1	W1	Output for heating stage number 1.
8 – Heat 2	W2	Output for heating stage number 2.
9 – Economizer Output	EC	0-10 VDC analog fresh air damper / economizer output.
10 – Analog Heat Output	AO	0-10 VDC analog heating output.
11 – RS	RS	Remote room or return air temperature sensor input.
12 – MS	MS	Discharge air temperature sensor input
13 – AI1	AI1	0-10 VDC analog input for CO2 transmitter
14 – Scom	Scom	Reference input for AI, RS, OS and MS
15 – OS	OS	Outside air temperature sensor input
16 – AI2	AI2	0-10 VDC analog input for airflow transmitter

TYPICAL APPLICATION

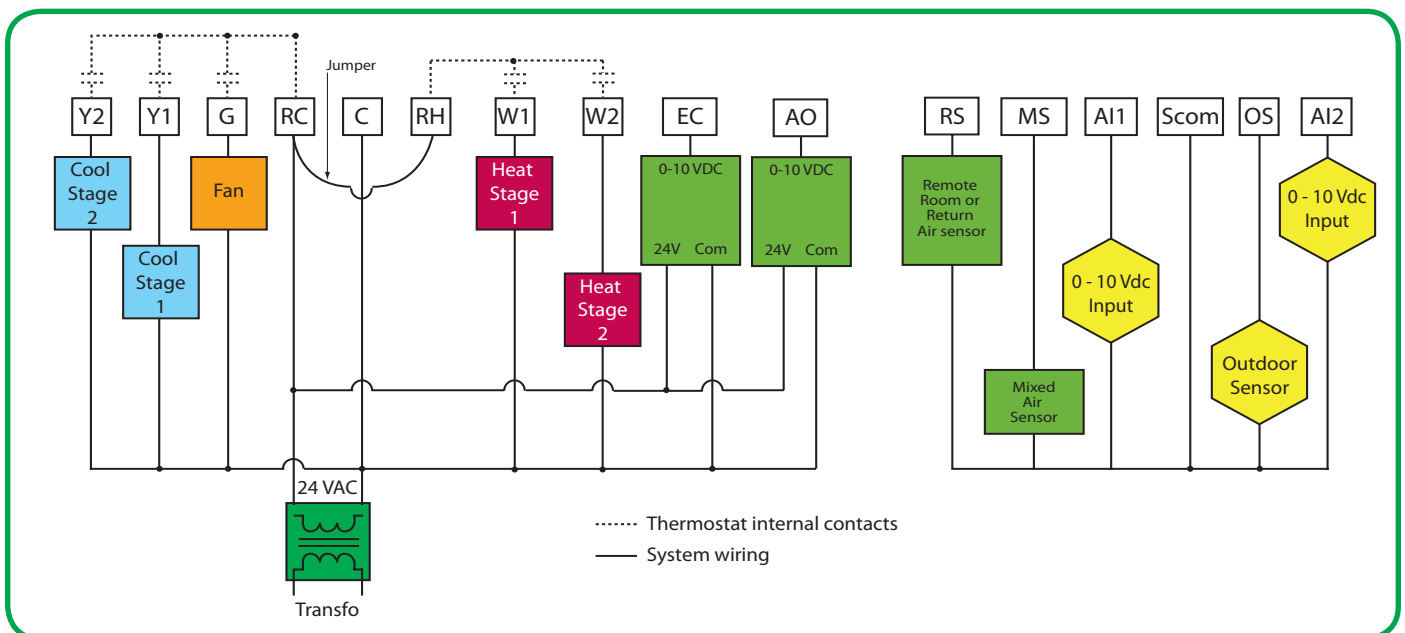

Main outputs wiring

Wiring notes:

Note 1: If the same power source is used for the heating stages, install jumper across RC & RH. Maximum current is 2.0 amps.

Note 2: Economizer and all analog outputs and inputs use a half bridge rectifier. Reference of the control signal is the common of the power supply of the Terminal Equipment Controller. (Terminal C).

Note 3: Electromechanical contacts are to be used with the digital inputs. Electronic triacs cannot be used as mean of switching for the input. The switched leg to the input for the input to activate is terminal C (common)

Note 4: The transformer of the unit provides power to the Terminal Equipment Controller and the additional loads that will be wired to the Terminal Equipment Controller.

Proportional Heat Control

The Schneider Electric SE7600E IAQ controller has the ability to maintain a minimum heating supply temperature by using an analog 0-10VDC proportional output instead of using the staging outputs which will cause the unit to cycle. Using a full proportional output to maintain the minimum heating supply temperature can increase cost savings and less wear and tear on HVAC equipment.

Indoor Air Quality Control Standards

The IAQ control is achieved by the SE7600E controller through CO2 level and minimum fresh air control. The building CO2 level has to respect the local building codes. The recommended outdoor air flow per the ASHRAE standard for office buildings (Air class 1) is as follows:

Table from: ASHRAE Standard 62.

Occupancy Category	People Outdoor Air Rate R_p cfm/person	Area Outdoor Air Rate R_a cfm/ft ²	Notes	Default Values		Air Class
				Occupant Density (see Note 4) #/1000 ft ²	Combined Outdoor Air Rate (see Note 5) cfm/person	
Office Buildings						
Office space	5	0.06		5	17	1
Reception areas	5	0.06		30	7	1

AI1 CO2 Sensor Input Operation

The SE7600E controller features a 0-10VDC input (AI1) that is used for monitoring using any 0-10VDC 0-2000 PPM sensor or to control the building CO2 level.

Using any 0-10VDC value for monitoring

If the AI1 input is used for monitoring purposes only (even if monitoring CO2 with a CO2 sensor), the AI1 parameter should be set to **None** (not CO2).

The value of the AI1 input can then be monitored at the network level (BACnet front end) under:

- AI1 value BACnet™ object (in VDC)

Locally at the controller, the value of AI1 can only be obtained by measuring the voltage between Sc0m and AI1 using a voltmeter. The value of AI1, if AI1 parameter is set to **None**, will not be displayed on the controller's screen at any time.

Using a 0-10VDC CO2 sensor for control purposes

If the AI1 input is used with a CO2 sensor for control purposes, the AI1 parameter should be then set to CO2. In this case, a CO2 value will be displayed at the end of the configuration parameters list showing the CO2 level measured by the sensor in ppm (parts per million).

The value of the AI1 input will also be displayed at the network level under:

- Room CO2 Value BACnet object (in ppm)
- AI1 value BACnet object (in VDC)

When AI1 parameter is configured to CO2, **the CO2 control is enabled only in Occupied mode**. The SE7600E will use these CO2 values to determine the building's CO2 Level for the IAQ control sequence.

INDOOR AIR QUALITY & SEQUENCE OF OPERATIONS

The fresh air damper can be controlled through more than one sequence to achieve different control strategies such as free cooling (economizer mode), minimum fresh air control and CO2 level control. Here are the control sequences available:

Note: For the sequences mentioned below, the following conditions must be met in order for the sequences to be performed as stated:

- Max Pos parameter value must be greater than Min Pos Parameter value.
- Max CO2 parameter value must be greater than Min CO2 Parameter value.
- Max FA parameter value must be greater than Min FA Parameter value.

Economizer Control Mode Only

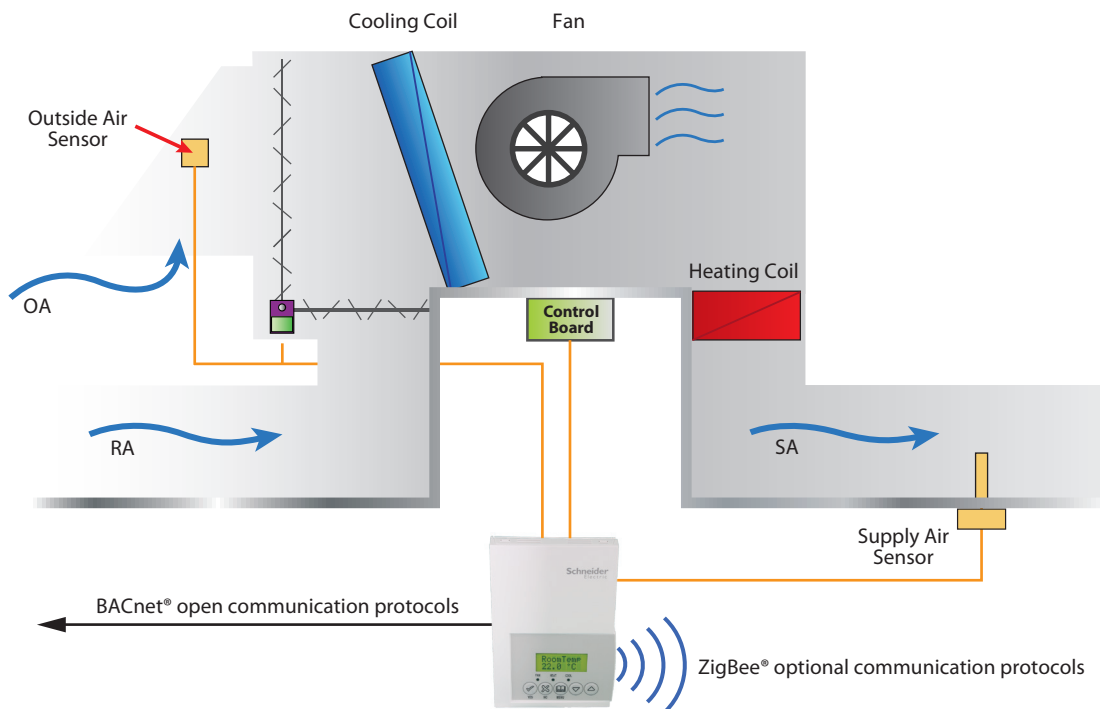

If the fresh air damper is to be used only for free cooling purposes (economizer mode, without fresh air measurement station or CO2 control), only the Min Pos parameter and the free cooling sequence will be active.

- **The FA Range parameter should be set to 0 CFM. (Default Value = 0 CFM)**
- **Set the Chngstpt parameter to desired value which free cooling is enabled. (Default Value = 55°F)**

If the outside air temperature is greater than the changeover setpoint, then normal mechanical cooling will be used. If the outside air temperature is less than or equal to the changeover setpoint, then free cooling will be enabled and mechanical cooling stages will be locked out.

Economizer Mode and Fresh Air Measurement Station

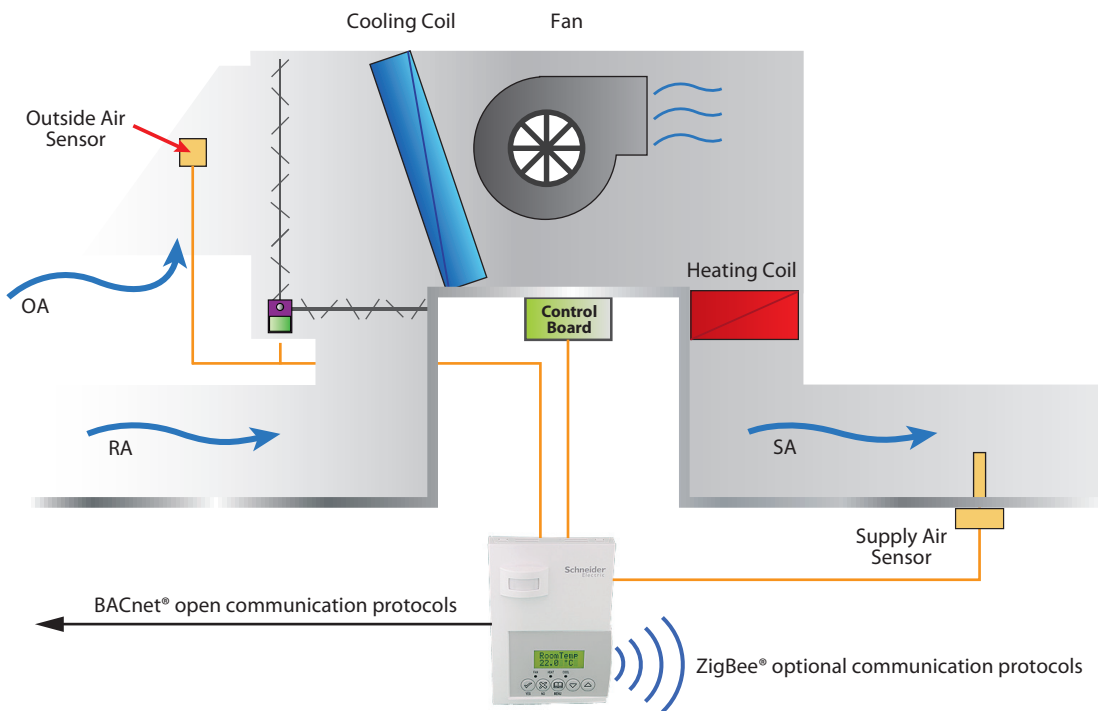

If the fresh air damper is to be used for both free cooling and minimum fresh air volume control (economizer mode and fresh air measurement station, but without CO₂ level control), only the Min FA parameter and the free cooling sequence will be active.

- **The FA Range parameter should be set to a value higher than 0 CFM (0 CFM disables the fresh air control).**
- **Min FA (minimum fresh air) parameter should be set to the desired level.**

The FA Range parameter value should be set to the maximum capacity of the fresh air measurement station. Therefore the relationship between air volumes and input signals can be established. For example, if the fresh air station capacity is 10450 CFM, set FA Range to 10450.

This will set the relationship of **0 VDC = 0 CFM** and **10VDC = 10450 CFM**.

Economizer Mode and CO₂ Level Control

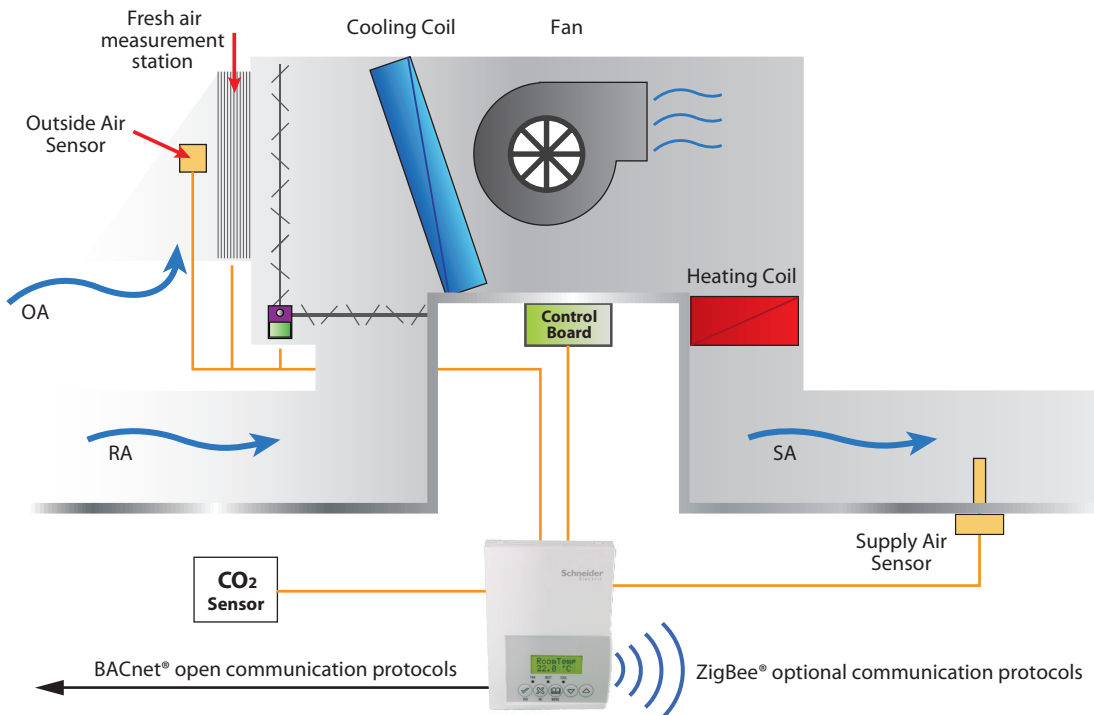

If the fresh air damper is to be used for both free cooling and CO₂ level control (economizer mode and CO₂ level control, but without fresh air measurement station), only the Min Pos, Max Pos, Min CO₂ and Max CO₂ parameters as well as the free cooling sequence will be active.

- The FA Range parameter should be set to 0 CFM.
- Set AI1 parameter to CO₂ (0 VDC = 0ppm ; 10VDC = 2000ppm)
- Min Pos, Max Pos, Min CO₂ and Max CO₂ parameters should be set according to the required setting.

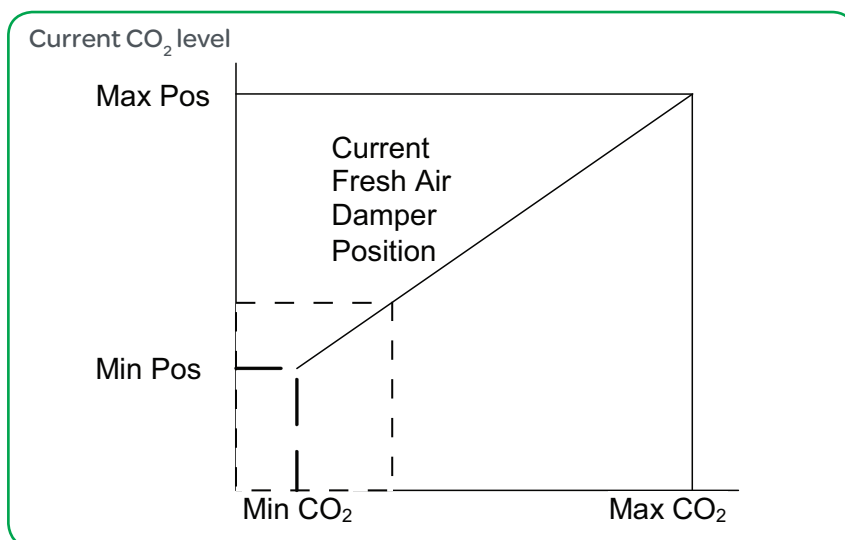

The higher value between free cooling output and interpolation output between the above graphic will be the signal sent to the fresh air damper.

Economizer Mode, CO₂ Level Control and Fresh Air Measurement Station

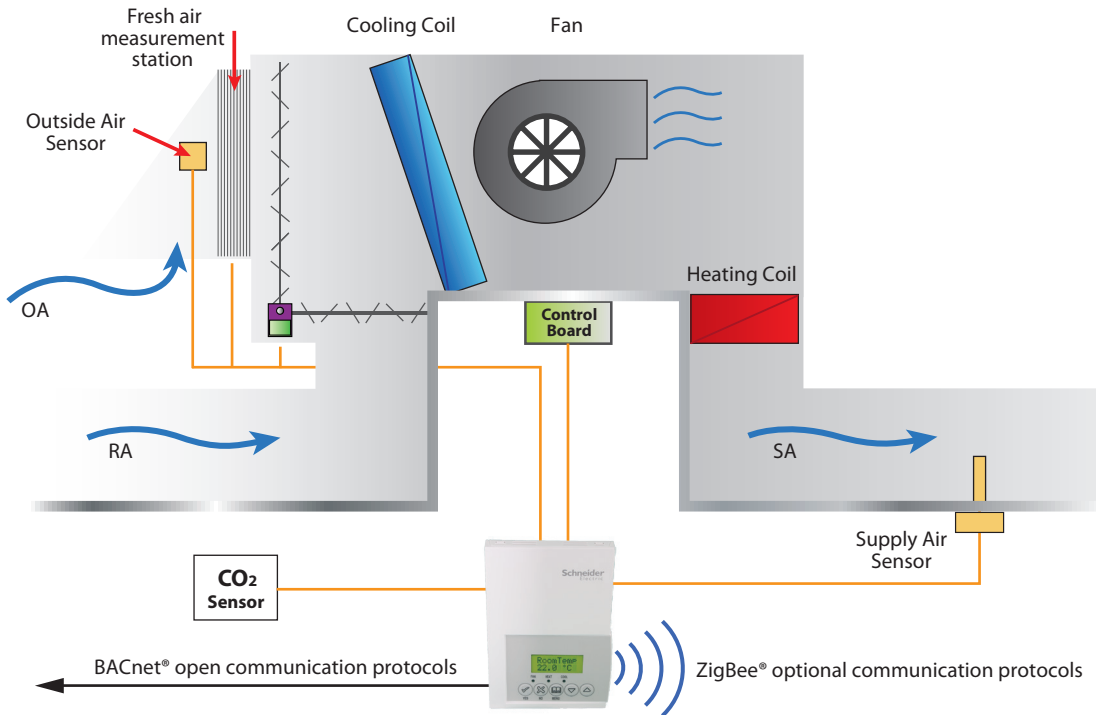

If the fresh air damper is to be used for both free cooling and CO₂ level control with a fresh air measurement station, only the Min FA, Max FA, Min CO₂ and Max CO₂ parameters as well as the free cooling sequence will be active.

- The FA Range parameter should be set to something other than 0 CFM.
- Use an air flow transmitter to read fresh air level with AI2 input (0-10 VDC input)
- Min FA, Max FA, Min CO₂ and Max CO₂ parameters should be set according to the required setting.

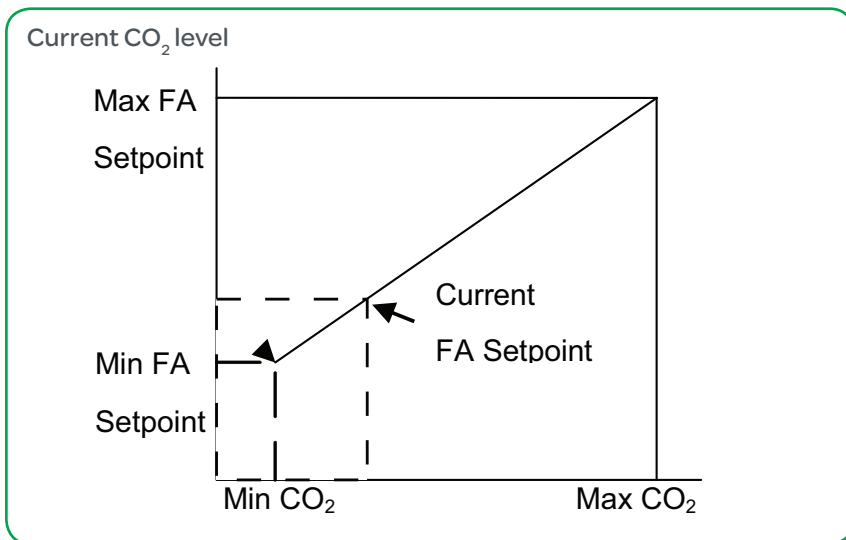

The higher value between free cooling output and interpolation output based on the above graphic will be the signal sent to the fresh air damper. If the occupancy is unoccupied, then the CO₂ control output will be 0%.