

Powers™ Controls

ET 134 Low Temperature Detection Thermostat

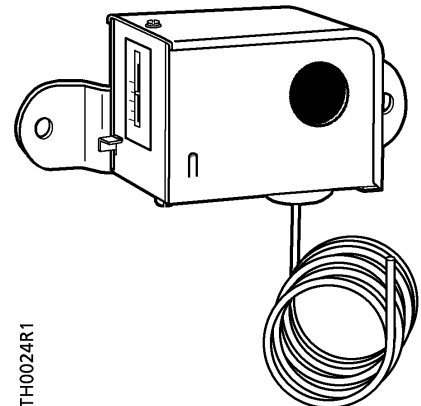

Description The Electric Low Temperature Detection Thermostat is a remote bulb instrument with a Single-Pole Double-Throw (SPDT) switch which closes and opens a circuit in both directions.

- Features**
- Compact and sturdy
 - Adjustable range with fixed differential
 - Unaffected by ambient temperature at case
 - Manual or automatic reset available
 - The set point adjustment screw is accessible at the bottom of the control or at the top with the cover removed
 - Mounting bracket standard

Product Numbers

Description	Product Numbers
Low Temperature Detection Thermostat Automatic reset	134-1510
Manual reset	134-1511

Warning/Caution Notations

WARNING:		Personal injury/loss of life may occur if a procedure is not performed as specified.
CAUTION:		Equipment damage, or loss of data may occur if the user does not follow a procedure as specified

Application

The electric low temperature detection thermostats are especially suited for sensing low temperature conditions to avoid freeze-up of hydronic heating coils, cooling coils, liquid heating pipes and similar applications. Typically, the switch opens an electrical circuit to stop the supply fan motor when the temperature at the sensing element falls below the setting of the instrument.



WARNING:

The low temperature detection thermostat is designed for use only as an operating control. Where an operating control failure would result in personal injury and/or loss of property, it is the responsibility of the installer to add devices (safety, limit controls) or systems (alarm, supervisory systems) that protect against, or warn of control failure.

Specifications

Switch action	SPDT
Range	35 to 45°F (2 to 7°C)
Maximum bulb temperature	250°F (121°C)
Ambient temperature at thermostat	0 to 140°F (-18 to 60°C)
Differential	
134-1510	12°F (6.7°C)
134-1511	Temperature must be 12°F (6.7°C) above cutout point before control can be reset
Bulb	1/8-inch (3.2 mm) x 20 feet (6 m)
Capillary length	4 feet (1.2 m)
Sensing element	Vapor filled
Reset type	See <i>Product Number</i>
Electrical ratings	See <i>Table 1</i>
Material	
Case	0.62-inch (1.57 mm) cold rolled steel
Cover	0.32-inch (0.81 mm) cold rolled steel
Conduit opening	7/8-inch (22 mm) for 1/2-inch conduit
Finish	Gray enamel
Weight	1.8 lbs. (0.8 kg)
Dimensions	See <i>Figure 4</i>
Approvals	UL file SA3863 CSA File LR948

Operation

Any 1-foot length of the element subjected to temperatures below the temperature setting of the thermostat will actuate the thermostat switch mechanism regardless of the temperature being sensed by the remainder of the element. The sensing element is unaffected by the ambient temperature at the thermostat if it is warmer than the set point temperature.

The 134-1511 thermostat has a manual reset feature. (See *Figure 5*.)

NOTE: The reset lever must be pressed manually and released to resume normal fan system operation.

Operation, Continued

Table 1. Electrical Ratings.

Motor Ratings	120 V	208 V	240 V
A.C. Full Load Amps	16	9.2	8
A.C. Locked Rotor Amps	96	55.2	48
Non-inductive Amps	16	9.2	8
Pilot Duty -- 125 VA		24 to 277 Vac	

Mounting and Installation

General Guidelines

- Locate the sensing element in the downstream side of the coil.
- Locate the case and bellows where the ambient temperature is always warmer than the set point.
- Install the thermostat case so that the reset button is readily accessible and the element bellows point down.
- Avoid sharp bends or kinks in the sensing element.
- Install as much of the bulb as possible in a horizontal plane. If too much of the bulb is vertical, it will not operate properly.

Large Walk-in Ducts (Figure 1)

1. Attach the mounting bracket to the thermostat case with the two round head screws provided.
2. Mount the two perforated steel strap hangers inside the duct with the wide part of the hanger strap parallel to the air flow.
3. Drill a hole through the side of the duct. With the bulb still coiled, thread the bulb through the hole using a rotary movement.
4. Mount the thermostat case on the outside of the duct.
5. Carefully uncoil the bulb avoiding sharp bends or kinks in the sensing element.
6. Mount the bulb in a horizontal serpentine manner. Attaching the bulb to the strap as shown in the detail in *Figure 1*.

The installation is now complete.

For an alternate method of mounting, use coil clips (part number 356-115) in the fins to hold the bulb in a horizontal serpentine pattern.

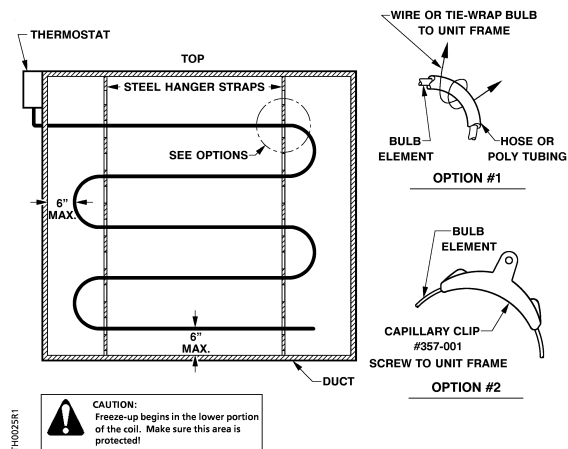

Figure 1. Typical Mounting in Walk-in Duct.

Mounting and Installation, continued

Limited Access Ducts

(Figure 2)

1. Attach the mounting bracket to the thermostat case with the two round head screws provided.
2. Attach a mounting flange (part number 808-412) on the opposite side of the duct (near the bottom) from where the thermostat will be mounted.
3. Mount a second flange on a 8-inch by 4-inch sheet metal plate. Cut an access opening for the bulb on the duct diagonally across from the duct mounted flange. Drill mounting screw holes for the sheet metal plate.
4. Cut a length of copper tubing to fit diagonally across the duct. Stretch out the bulb and wrap it around the tubing.
5. Insert the tubing and bulb through the access hole and into the duct-mounted flange. Fasten the 8-inch by 4-inch sheet metal plate to the duct.
6. Mount the thermostat case on the outside of the duct.

The installation is now complete.

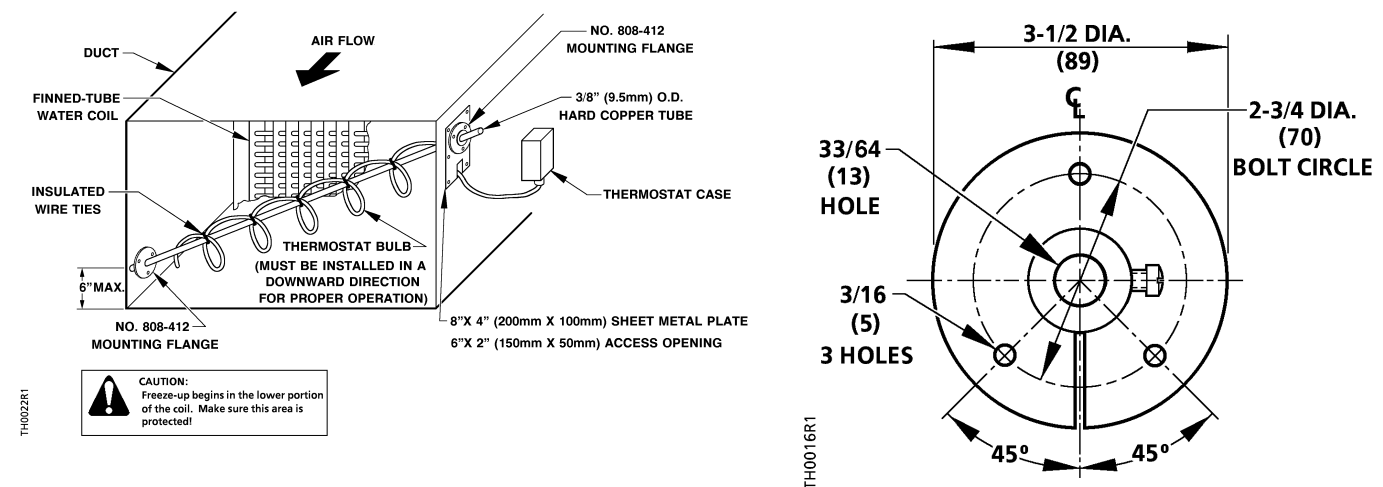

Figure 2. Bulb Mounting for Limited Access Ducts with Mounting Flange.

Wiring



WARNING:

Disconnect the power supply before wiring connections are made to avoid possible electrical shock or damage to the equipment.

All wiring should conform to the National Electrical Code and local regulations. Loads exceeding the rating of the thermostat should be handled by means of a relay or motor starter.

Red is common. See *Figure 3* for terminal identification.

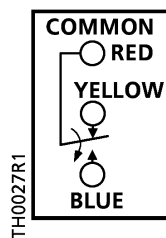

Red to Yellow opens on temp. decrease below set point.

Red to Blue closes on temp. decrease below set point.

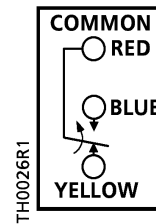

Red to Blue closes on temp. decrease below set point.

Red to Yellow opens on temp. decrease below set point.

Figure 3. Terminal Identification.



CAUTION:

Use terminal screws furnished (#8-32 x 1/4-inch binder head screw). Substitution of other screws can cause problems in making proper connections.

Dimensions

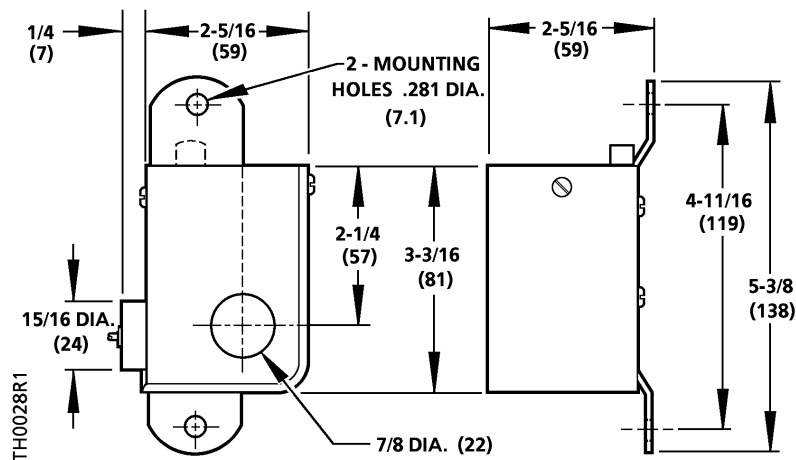

Figure 4. Dimensions of the 134-1510 and 134-1511 Thermostat.

Adjustment

Change the set point by turning the adjusting screw until the pointer is opposite the desired cutout point.

The adjusting screw is accessible at the bottom of the thermostat or at the top when the cover is removed. See *Figure 5* for the location of the adjusting screw.

The direct reading scale was calibrated at 800 feet (244 m) above sea level at 35°F (2°C). For critical installations in higher altitudes raise the set point by 1°F (0.56°C) for each 1,800 feet (549 m) of elevation.

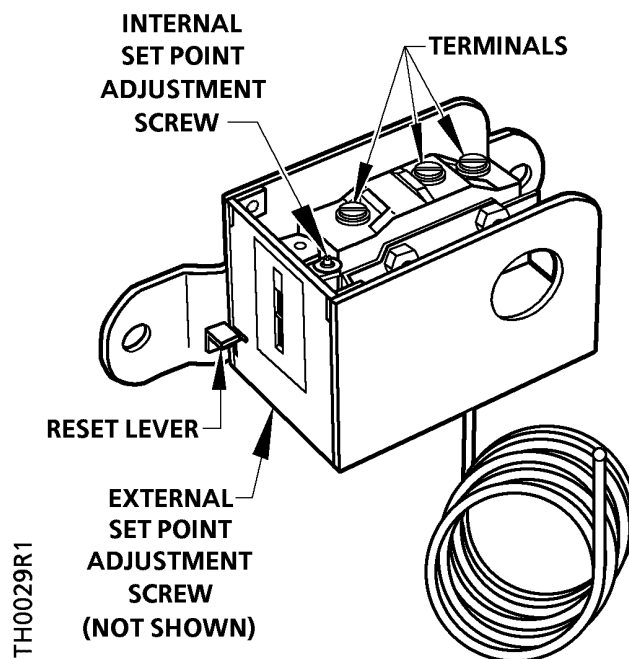

Figure 5. Internal View of Thermostat.

Troubleshooting

Observe a complete operating cycle to be sure that all components function correctly.

Service

There is no servicing of the thermostat. Replace if inoperative.

Information in this publication is based on current specifications. The company reserves the right to make changes in specifications and models as design improvements are introduced. Powers is a registered trademark of Siemens Industry, Inc. Product or company names mentioned herein may be the trademarks of their respective owners. © 2005 Siemens Industry, Inc.